

# Viplax-I

## Users Manual



Viplax-I Transmitter- / Receiver Unit



# Table of Contents

Introduction.....	8
Safety Restrictions.....	8
General Description of the Viplax-I Transmission System.....	9
Shipping List.....	9
Accessories.....	9
Viplax-I Transmitter (Handheld version).....	11
Technical Description.....	11
Adjustment of the gain factor.....	12
Adjustment of the Window Comparators of the Transmitter.....	14
Default Switch Settings:.....	16
Visualisation.....	16
Auxiliary Port.....	17
Power supply.....	18
Maintenance of the Transmitter.....	19
Viplax-I Transmitter (Eurocard version).....	20
The Orientation of the Comparator DIP switches.....	20
The used Power Supply.....	20
Additional I/O.....	21
Analog Input or Sensor Plug.....	22
Viplax-I Receiver.....	23
Technical Description.....	23
Functional Description of the Error Logic.....	24
Error Processing System.....	24
Link Synchronisation.....	24
First Fault Memory.....	25
Signal LEDs.....	28
Digital Interface.....	28
Digital I/O-Ports.....	29
Power Supply for the Receiver.....	30
Power Up Sequence.....	30
Maintenance of the Receiver.....	31
Maintenance of the Transmission System.....	31
Offset Calibration.....	31
Viplax-I Service-Software.....	32
Viplax-I Interface Options.....	32
USB Option: Installing a Driver for a Virtual USB/RS232 Port.....	32
Screenshots of the Installation Process.....	33
Verifying the COM-Ports.....	35
Viplax-I Configuration Program.....	35
TCP/IP Ethernet-Interface:	
Using a Web-Browser for Viplax-I Configuration.....	38
Overview.....	38
Getting started.....	38
Viplax-I Start Page.....	39
Viplax-I Login (HTTP-Authentication).....	40

Viplax-I Specific Adjustments.....	40
Change Password.....	41
Network Settings.....	42
TCP/IP Protocol SNMP (Simple Network Management Protocol).....	43
Changing the FPGA-Configware.....	47
Changing the Microcontroller Firmware (MiniFlex only).....	47
Software Support.....	47
Appendix.....	48
Technical Data.....	48
Transmitter_V3_RevA, Receiver_V3_RevA:.....	48
Connector Pinouts.....	50
Test Procedure for Transmitter and Receiver.....	54
Transmitter Functional Tests:.....	54
Receiver Functional Tests:.....	54
Printed circuit diagrams.....	55
Accessories.....	56
Receiver Power Supply.....	56
Backplane Basic and Basic-Bi.....	58
Repair.....	61

## Table Index

Table 1: Selectable gain factors and the resulting total gain $v$ over the maximum input voltage for the transmitter revision C and revision C10.	12
Table 2: Adjustment of the comparator functionality via SW2. Remark: All other switches of SW2 are not used	14
Table 3: Factory settings of the DIP-switches.	15
table 4: Auxiliary port – Lemo header.	16
table 5: Auxiliary port – 10 pin header.	16
table 6: Power supply.	17
Table 7: Additional I/O	20
table 8: Front panel female plug.	21
Table 9: Error Signals wired to the connector X5.	26
Table 10: Error Signals wired to the connector X10.	26
Table 11: Signalisation of the USB type.	27
Table 12: Signalisation of the TCP/IP type.	27
Table 13: Digital Data wired to the connector X5.	28
Table 14: Digital Interface wired to connector X11.	28
Table 15: Supply voltages for the receiver connected via connector X5.	29
Table 16: Connector SV1; Receiver.	49
Table 17: Connector SV2; Receiver.	49
Table 18: Connector X5; Receiver.	50
Table 19: Connector X6; Receiver.	51
Table 20: Connector X7; Receiver.	51
Table 21: Connector X10; Receiver.	52
Table 22: Connector X11; Receiver.	52

Table 23: Connector SV2; Transmitter.	52
Table 24: Pinout of the power supply connector.	74
Table 25: Pin-out of the Terminals X5 to X10 of the Backplane.	77

## Figure Index

Figure 1: Viplax-I Transmitter (handheld version).	11
Figure 2: Board Layout of the Viplax-I Transmitter (Handheld Version): DIP-switches for gain adjustments and the comparator.	12
Figure 3: Disassembly of the transmitter PCB to the left side!	12
Figure 4: GAIN adjustment of the Viplax-I Transmitter via DIP-switches.	13
Figure 5: COMP-SEL SW2 and CMP-LVL SW1 of the Viplax-I Transmitter.	14
Figure 6: Lemo 5B-2	17
Figure 7: Lemo 0B-2	18
Figure 8: mechanical Layout of the stand alone transmitter power supply	18
Figure 9: Orientation of the comparator DIP switches	20
Figure 10: Lemo 5B-2	22
Figure 11 :Viplax-I Receiver.	23
Figure 12 :Viplax-I Receiver (front view).	26
Figure 13: Windows hardware facility assistant	33
Figure 14: Selection of the driver directory	33
Figure 15: Finish the driver installation; Serial converter	34
Figure 16: Finish the driver installation; USB serial port driver	34
Figure 17: USB Serial Port (COMx)	35
Figure 18: Viplax-I configuration program, serial interface	35
Figure 19: Viplax-I configuration program, thresholds	36
Figure 20: Viplax-I configuration program, error handling	36
Figure 21: Viplax-I configuration program, offset adjustments	37
Figure 22: Welcome-Screen	39
Figure 23: User Authentication	40
Figure 24: Viplax-I Adjustments	40
Figure 25: Change password	41
Figure 26: Viplax-I Network settings	42
Figure 27:	75
Figure 28:	75
Figure 29: Front- und Rear-view of the Backplane Basic-Bi	77
Figure 30: Backplane Basic-Bi rear view	77

## History

<i>Issue</i>	<i>Date</i>	<i>Reason For Changes</i>
01	20040517	Initial issue.
02	20040603	Added schematics and PCBs.
03	20050601	English Version.
04	20051115	Minor corrections.
05	20060402	New case type and different connectors (optional).
06	20060925	Added adjustment of the gain for the transmitter C10.
07	20060925	The BNC output has up to now a maximum amplitude of 10V at 50 Ohm.
08	20060925	Updated technical data.
09	20060925	Added resynchronisation state machine feature.
10	20060925	Correction of the figure index.
11	20061114	Changed testing behaviour.
12	20061114	Removed outdated schematics.

## References

[1]

# Introduction

Ladies and Gentlemen,

Thank you for purchasing Viplax-I from Inventronik GmbH. With the purchase of this product you have acquired a high-quality Analog-Signal transportation system. Please read this user manual completely before start-up. This document will give you comprehensive information regarding Viplax-I capabilities and how you can most efficiently use them. Inventronik GmbH is endeavored to keep the most current information concerning our products at your disposal. On our website ([www.inventronik.de](http://www.inventronik.de)) the newest documents are available for you to download.

## Safety Restrictions

Inventronik GmbH is proud to supply you with a high-quality device, nevertheless we cannot guarantee that this module works under all possible conditions without failure. Do not use this product in applications, where damage in the module could lead to direct danger for humans, e.g. medical systems, protection devices and such.

Inventronik GmbH cannot be held in any way responsible for general or specific damages caused by abuse or misuse of our products.

This product is conceived exclusively for use with the specified voltages. We recommend the use of the Viplax-I power supply. Higher voltages can lead to malfunction and/or the total loss of the module. **Please only use certified power supplies.**



# General Description of the Viplax-I Transmission System

Viplax-I is a system designed for transmitting analog bipolar signals with little regard to the difference in electrical potential. Electrical isolation has been accomplished by using a fiber optic line between transmitter and receiver. The analog input signal on one end is converted to a digital signal, serialized and sent via highspeed fiber optic link to the receiver unit.

The receiver unit reverses the process, converting the serial data with minimal delay and extreme accuracy back into the analog signal measured by the transmitter.

A high-quality, low-impedance output-driver delivers the recovered analog signal to loads with small impedance e.g. correctly terminated coaxial cables at 50 or 75 Ohm. The digital resolution of the system is 14 bit. The analog bandwidth lies at about 2.5MHz (3dB).

Besides the analog data transmission there are additional features distinguishing Viplax-I from other commercial systems. For instance, digital data processing, fast and accurate comparator functions, comfortable software, easy offset calibration, and support for software or hardware add-ons.

For further information regarding these additional features please refer to the dedicated chapters in this document.

## Shipping List

A standard set of Viplax-I transmission systems consists of the following components:

- A transmitter unit: Viplax-I Transmitter.
- A power supply.
- A fiber optic line with a length of 2m (other lengths are available on request).
- A receiver unit.
- For configuration: a 1 meter USB or TCP/IP cable (depending on the type of receiver).
- CD-Rom with datasheets, circuit diagrams, documentation and system software.

## Accessories

Currently available accessories for Viplax-I:

- Power supply for the receiver: 3U, 14HU plug in unit for 19“ rack mount systems.
- Fiber optic links: custom lengths
- USB or TCP/IP interface cables in several lengths.
- Backplane Basic: backplane for 19 inch 3U systems. This printed circuit board wires a Viplax-I receiver power supply with one receiver.
- Backplane Basic-Bi: backplane für 19 inch 3U systems. This printed circuit board wires a Viplax-I receiver power supply with two receivers.

If you have need of special equipment please contact Inventronik GmbH ([www.inventronik.de](http://www.inventronik.de)).

# Viplax-I Transmitter (Handheld version)

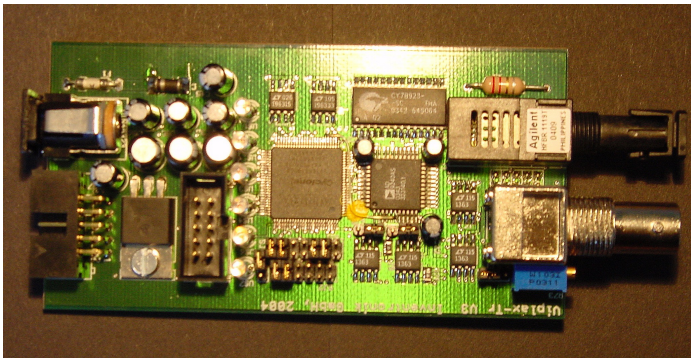

Figure 1: Viplax-I Transmitter (handheld version).

## Technical Description

The Viplax-I transmitter has two different case options. The a 3U unit is for 19" rack-mount systems and the compact, high frequency resistant, metal case, is suited for high voltage applications. There are only a few adjustments, and three cables necessary to operate the transmitter unit. The following description is specifically for the handheld version, but the 3U 19" version operates the same way, except the power supply is connected via a backplane Basic or Basic-Bi.

The transmitter is a powerful unit, compact, easy-to-install and maintenance free thanks to the use of modern electronic components. It's main elements are; a high quality analog digital converter with high resolution, a modern Field Programmable Gate Array (FPGA), a high-speed bitstream converter and a high-speed optical transmitter unit.

The data processing in the transmitter unit functions as follows: a BNC or SMB-jack connects the analog input signal. One or the other is available for the handheld unit, both for the rack mount version. An input amplifier with 1M $\Omega$  input impedance has gain factors of 1.0; 2.0; 5.0 and 10.0. The selection of the desired gain factor is done via DIP-switches (Figure 2).

To avoid signal distortion through aliasing effects there is a 'Bessel' filter of 5<sup>th</sup> order (30dB/octave) between the preamplifier and the analog digital converter.

The AD converter has a resolution of 14bit and a sampling rate of 10 MSps transmitting analog signals with a bandwidth of 2.5MHz.

In addition to the AD payload there are four system check bits to transmit. The status of the power supply, the AD converter overflow bit, the comparator status and a freely usable FLAG „GP\_BIT7“, which is connected to pin 9 of the auxiliary port.

Finally all parallel digital data are serialized, transmission check bits are generated and send through high speed optical link.

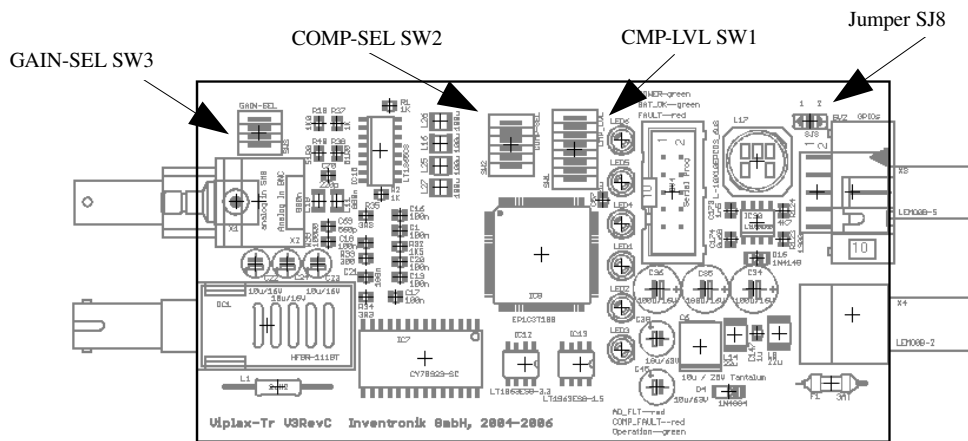

Figure 2: Board Layout of the Viplax-I Transmitter (Handheld Version): DIP-switches for gain adjustments and the comparator.

## Adjustment of the gain factor

**Important notice:** *Do not try to remove the board from the right side of the case!* This may damage either the case or the circuit board.

The only way to remove the circuit board from the handheld case is as shown in the figure below.



Figure 3: Disassembly of the transmitter PCB to the left side!

The first step is to disassemble the circuit board from its case. Remove the cap which covers the BNC/SMB jack and the ST jack on the left side of the fiber optic transmitter. Afterwards position the board as shown in figure 2 and you will find the gain DIP switches (GAIN\_SEL SW3) in the upper left corner right above the BNC/SMB connector.

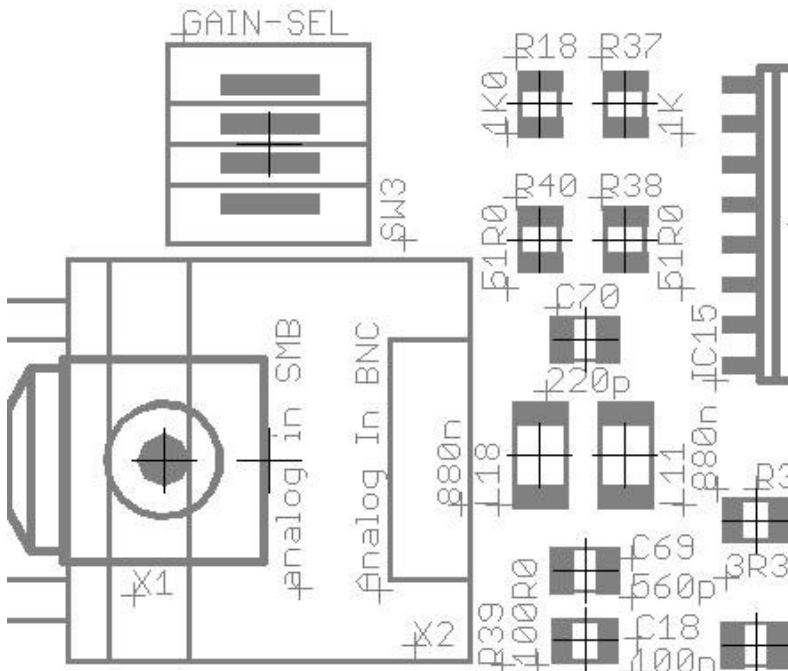

Figure 4: GAIN adjustment of the Viplax-I Transmitter via DIP-switches.

The adjustment of the gain factor is for the Viplax handheld transmitter revision C and for the Viplax handheld transmitter revision C10 slightly different. The version of the transmitter is labeled on the top of the printed circuit board as follows:

**Viplax-Tr V3RevC** for the revision C type and

**Viplax-Tr V3RevC10** for the revision C10 type.

As the transmitter revision C provides four gain factors selectable via the switch 3 (GAIN-SEL), the transmitter revision C10 provides three gain factors and one attenuator selectable via GAIN-SEL.

The gain  $v$  is adjusted for the preamplifier by GAIN-SEL SW3 (see figure 4). Only one switch of the gain select switches must be turned on. Additionally, the attenuator switch may be turned on. In rows 4 and 5 of Table 1 the gain factors of the Viplax-I system (transmitter-receiver) are referenced to the analog outputs (BNC/SMB) of the receiver.

The output, connected to the BNC jack has a maximum amplitude of +/- 10V, and the SMB jack has an amplitude of +/- 10V. The different gain factors are adjustable as follows:

<b>SW3:</b>	<i>1 - On</i>	<i>2 - On</i>	<i>3 - On</i>	<i>4 - On Revision C</i>	<i>4 - Revision C10:</i>
$U_{inmax}$	$\pm 10.0V$	$\pm 5.0V$	$\pm 2.0V$	$\pm 1V$	<i>on = :1</i> <i>off = :10</i>
$v$	1.0	2.0	5.0	10.0	<i>on = :1</i> <i>off = :10</i>
$U_{in} / U_{BNC}$	1.0	2.0	5.0	10.0	<i>on = :1</i> <i>off = :10</i>
$U_{in} / U_{SMB}$	1.0	2.0	5.0	10.0	<i>on = :1</i> <i>off = :10</i>

Table 1: Selectable gain factors and the resulting total gain  $v$  over the maximum input voltage for the transmitter revision C and revision C10.

**The maximum input voltage must not exceed 10V for the transmitter revision C and revision C10 with no attenuation and not exceed 50V for the revision C10 with attenuation! The attenuation is 'on', when Switch 4 is off.**

### Adjustment of the Window Comparators of the Transmitter

The absolute value of the comparator threshold is configured through DIP-switches COMP-LVL SW1 (see figures 2 and 5). The switch block is located above the FPGA (big square chip). Adjustment of the threshold is achieved in steps of 1%. Using the switches as 7bit binary, you need to encode the desired value. A switch in on position means a logic '1' and in off position a logic '0'. The switch labeled "1" is the least significant bit (LSB) and "7" is the most significant bit (MSB) of the 7 bit code. **Important: Switch 8 of switch block SW1 is used to enable the comparator (On = enable). Factory setting is Off!**

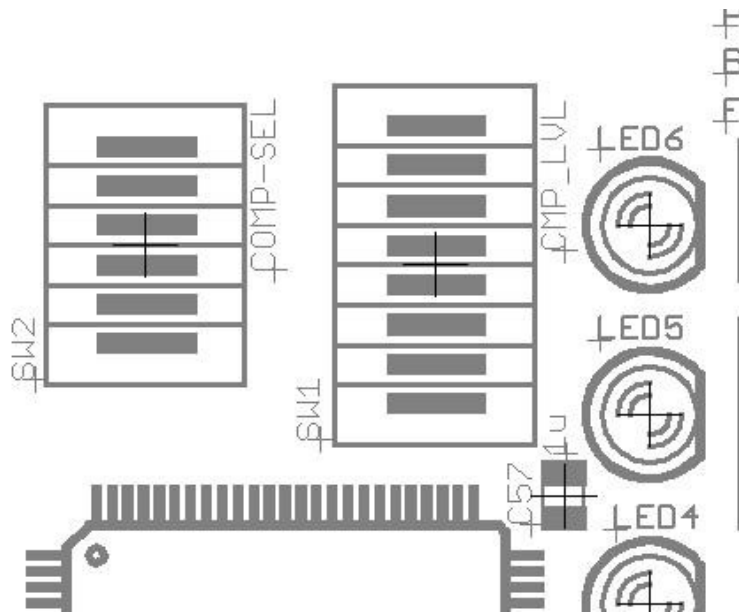

figure 5: COMP-SEL SW2 and COMP-LVL SW1 of the Viplax-I Transmitter.

Example: A threshold of 67% has a pattern of “On, Off, Off, Off, Off, On, On” (100011 = decimal 67).

Since there is a maximum of 127% adjustable, all values greater 100% are interpreted as 100%. The threshold value may be used for positive and negative comparator values. A threshold setting of 100% equals an A/D input signal of exactly 2.5V (absolute value). This means that the preamplified input signal must not exceed this value not to produce a A/D converter overflow or wrong comparator behaviour. With the switches COMP-SEL SW2 there are negative, positive or both comparators selectable (see Table 2).

<b>SW2 (2+1)</b>	<b><i>Description</i></b>
On/On	Comparator detects overstepping of positive and negative thresholds.
On/Off	Comparator detects overstepping of positive thresholds only.
Off/On	Comparator detects overstepping of negative thresholds only.
Off/Off	not used

Table 2: Adjustment of the comparator functionality via SW2. Remark: All other switches of SW2 are not used

Transmitter comparators are helpful if you want to supervise the input signal directly at the transmitter case. Otherwise we recommend to use the more powerful receiver comparators. These comparators allow easy adjustment through PC integration.

## Default Switch Settings:

The transmitter factory settings for the DIP-switches SW1-SW3:

<i>Jumper:</i>	<i>Adjustment</i>	<i>Remarks</i>
SW1 (7-1)	Off, On, On, Off, Off, On, Off	50,00%
SW2 (2-1)	On, On	both, positive and negative supervision
SW3 (4-1)	x1 (Off, Off, Off, On)	gain set to factor 1
SW1 (8)	Off	comparator inactive

Table 3: Factory settings of the DIP-switches.

## Visualisation

Six LEDs are located on the top cover of Viplax-I transmitter (handheld version). All LEDs are used for status and error indication:

1. **POWER:** power status. This LED indicates the correct function of the internal charge pump. The charge pump is used to create the negative voltage supply. The LED may be darker than the other to avoid unnecessary load of the charge pump.
2. **BAT-O.K.:** voltage supervision control. You may use a battery to power the Viplax-I transmitter. This LED detects its correct charge condition. If the transmitter is operated by a power supply, the LED statically is turned on.
3. **FAULT:** collective error. It indicates either a comparator threshold or an AD converter overflow error.
4. **AD-FLT:** overflow error of the AD converter. This LED indicates if the AD converter is driven into saturation by too high input signals. Solution is to reduce the input voltage or the amplification factor.
5. **COMP-FLT:** comparator threshold event. The LED indicates the input voltage falls outside of the adjusted thresholds.
6. **OPERATION:** indicates steady operation, a well initialized transmitter without system faults or other errors (no comparator- or AD converter errors and battery in good charge condition).



## Auxiliary Port

The Viplax-I transmitter unit (handheld type) is equipped with a 10 pin auxiliary port header or optionally with a 5 pin Lemo 0B female plug. Both carries the 9V..12V operating voltage, GND and some user defined input/output lines. The signals are dedicated for system enhancements (please contact Inventronik GmbH for usage).

The port connector Lemo 0B-5. It is located right behind the right panel (Figure 2). Figure 6 shows the front view on the handheld case.

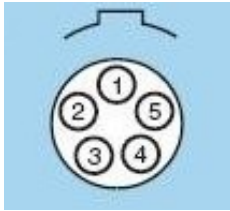

Figure 6: Lemo 5B-2

<b>Pin 1</b>	<b>Gnd</b>
<b>Pin 2</b>	<b>GPIO 1</b>
<b>Pin 3</b>	<b>GPIO 2</b>
<b>Pin 4</b>	<b>Vcc (9V..12V) or GPIO 3 (1)</b>
<b>Pin 5</b>	<b>Monitor (2)</b>

table 4: Auxiliary port – Lemo header.

(2) GPIO3 is the output signal of the digital comparator. It can be accessed by connecting the jumper SJ8 to position 2. The VCC output on this pin is selected by connecting the jumper SJ8 to position 1. For detailed information see the printed circuit layout and the schematics in this document or contact nventronik GmbH.

(2) Is a mirror of the input signal equipped with an impedance converter with a max. output voltage of 2.5V (max. output current 20mA).

The pin header (10 pin) is also located right behind the right panel (Figure 2). The table 5 shows the pinout of this header.

<b>Pin 1</b>	<b>GPIO 1</b>	<b>Pin 6</b>	<b>GPIO 5</b>
<b>Pin 2</b>	<b>GND</b>	<b>Pin 7</b>	<b>GPIO 6</b>
<b>Pin 3</b>	<b>GPIO 2</b>	<b>Pin 8</b>	<b>GPIO 7</b>
<b>Pin 4</b>	<b>GPIO 3(1)</b>	<b>Pin 9</b>	<b>GPIO 8</b>
<b>Pin 5</b>	<b>GPIO 4</b>	<b>Pin 10</b>	<b>VCCIO (3,3V)</b>

table 5: Auxiliary port – 10 pin header.

(1) GPIO3 is the output signal of the digital comparator. For detailed information see the printed circuit layout and the schematics in this document or contact nventronik GmbH.

## Power supply

The power supply with 9V...12V DC is used to power the Viplax-I transmitter (part of the delivery). The recommended setting is 9V. The connector type is Lemo 0B-2. Figure 7 shows the front view.

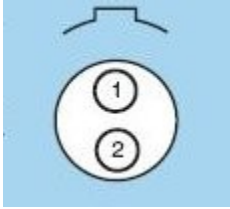

Figure 7: Lemo 0B-2

<i>Pin 1</i>	<i>Vcc (9V..12V)</i>
<i>Pin 2</i>	<i>Gnd</i>

table 6: Power supply.

The transmitter provides an optimized voltage control system to ease the use of a backup battery. Supervision of the battery charge condition is accomplished by a comparator. This status information is also available to the receiver unit.

The delivered power supply is build in 50Hz technique. **We do not recommend other power supplies such as switched mode power supplies. The usage of these modern supplies may reduce the analog signal quality dramatically!**

The layout of the drills of the of the original power supply is given in Figure 8.

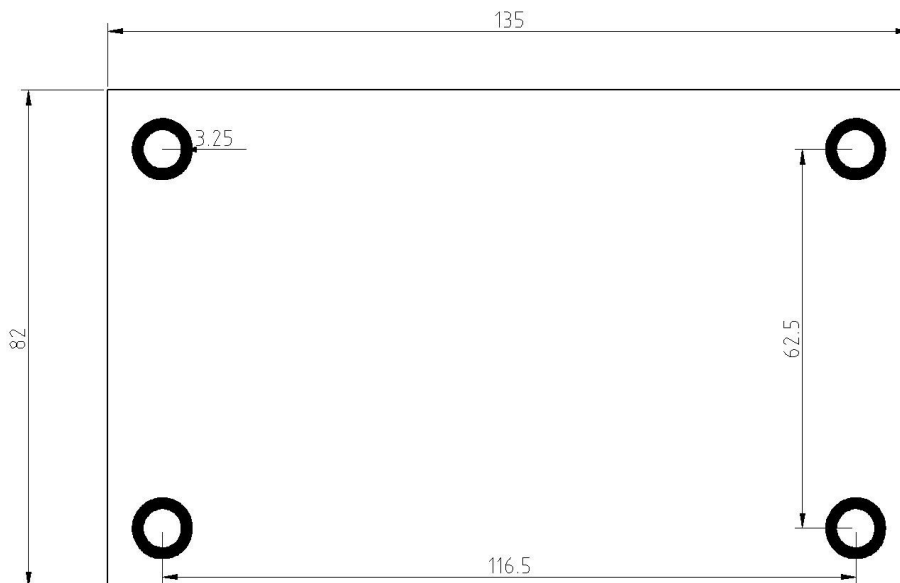

Figure 8: mechanical Layout of the stand alone transmitter power supply

## **Maintenance of the Transmitter**

Under normal circumstances the Viplax-I transmitter requires no maintenance. Merely, if the supply voltage polarity has been connected in a wrong way, it is possible that the transmitters internal fuse got blown and must be replaced. The fuse is the F1 on the PCB (PicoFuse). See also the layouts in the attachment to this document.

If the transmitter is not connected to a fiber optic line, a cap should protect the optical subsystem to avoid any damage.

Do not touch the fiber optic connector at its 'Ferrule'. If Viplax-I is not used, please cover the Ferrules with a dust caps.

# Viplax-I Transmitter (Eurocard version)

The eCard version of the Viplax-I transmitter is a 3U unit for 19" rack-mount systems. This version of the transmitter is basically the same as the handheld version. Therefore it is a good idea to read the specification of the handheld Viplax-I first. However there are differences which we will describe in this section of the handbook.

## The Orientation of the Comparator DIP switches

The layout of the eCard transmitter is of course different to the handheld versions. Therefore the placement of the DIP switches for the comparator settings is different as the following figure illustrates.

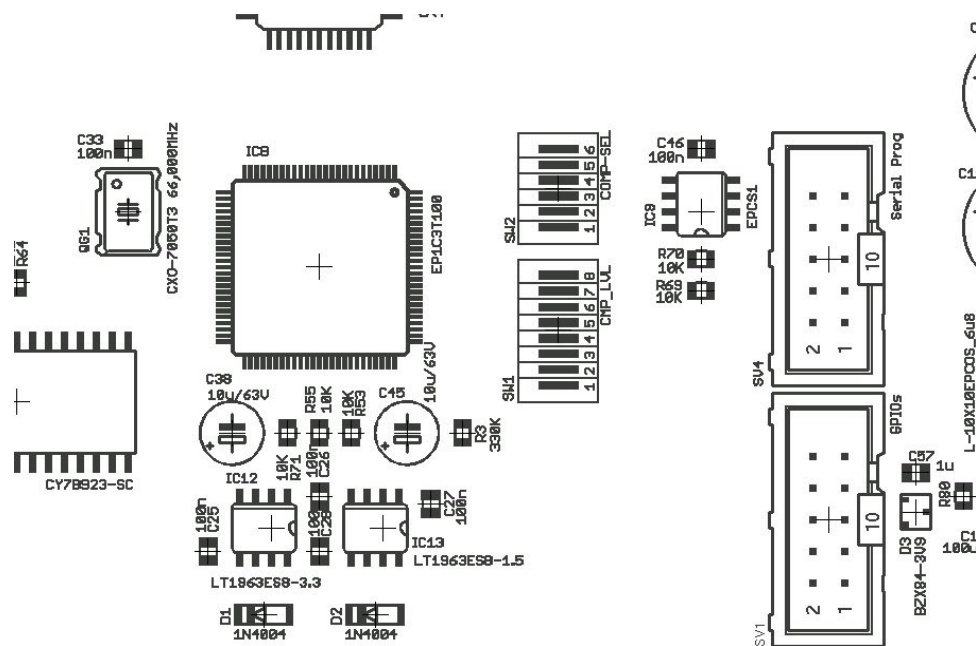

Figure 9: Orientation of the comparator DIP switches

## The used Power Supply

The power supply you want to use is from the same kind as the one for the Viplax-I receiver (see Power Supply for the Receiver). To interconnect the power supply and the Viplax-I eCard you will additionally need a backplane. Again you can use the same as we offer for the Viplax-I receiver (see Backplane Basic and Basic-Bi.).

## Additional I/O

Like Viplax-I handheld, there are additional I/Os available on the VG connector X5. These are dedicated for system enhancements (please contact Inventronik GmbH for usage). The table 7 below shows their usage.

<i>connector Pinof X5</i>	<i>Function</i>
X5-A1	Monitor (1)
X5-A17	Comp (Output fo the digital comparator)
X5-A18	GPIO
X5-A19	GPIO
X5-A20	GPIO
X5-A21	GPIO
X5-A22	GPIO
X5-A23	GPIO
X5-A24	Thermo (2)
X5-C3 – X5-C15	Gnd
X5-C18 – X5-C30	Gnd

Table 7: Additional I/O

(1) Is a mirror of the input signal equipped with an impedance converter with a max. output voltage of 2.5V (max. output current 20mA).

(2) This signal is active high.

The Thermocontact 'Thermo' is a supervision of the temperature of the Viplax shunt, which is separately available as an accesoire. The contact is normally closed and therefore a low indicates no error. The input on the eCard is equipped with a pull up resistor. If there is another sensor than the shunt connected to the Viplax-I eCard transmitter, there must be taken care of shorting the 'Thermo' input and ground. The connector is illustrated in the following section. Thus pins 2 and 4 of this connector must be shorted or another appropriate sensor must be connected. Otherwise the eCard indicates a fault.

The 'Thermo' contact is combined with the fault signal LOW\_BAT for there is never a LOW\_BAT in the eCard and there is no 'Thermo' contact in the handheld. The error handling is therefore the same as for the LOW\_BAT signal in the handheld version.

## Analog Input or Sensor Plug

This connector is compared to Viplax-I handheld more flexible. Besides the analog input there is also a digital input signal and a supply voltage of +/-15V. This makes it possible to connect additional special purpose sensors like the Viplax-I Shunt-100A. The port connector is Lemo 0B-5. It is located on the front panel of Viplax-I eCard. Figure 10 shows the front view of the female plug.

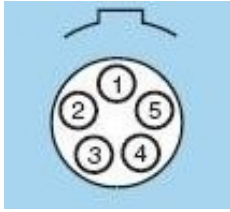

Figure 10: Lemo 5B-2

<b><i>Pin 1</i></b>	<b><i>Analog input</i></b>
<b><i>Pin 2</i></b>	<b><i>Digital input (max. 15V)</i></b>
<b><i>Pin 3</i></b>	<b><i>+15V</i></b>
<b><i>Pin 4</i></b>	<b><i>Gnd</i></b>
<b><i>Pin 5</i></b>	<b><i>-15V</i></b>

table 8: Front panel female plug.

# Viplax-I Receiver

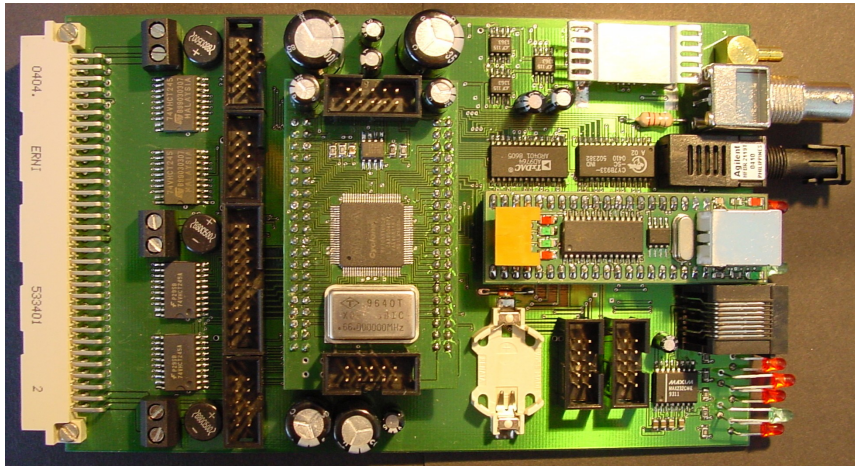

Figure 11 :Viplax-IReceiver.

## Technical Description

Digital data processing goes vice versa, compared to the transmitter. The received serial data stream will be converted into parallel equivalent. Transmission check bits indicate a valid reception. Next the system check bits and the user-bit GP\_BIT7 are extracted (see attachments: connector X6 pin number 8, (D\_OUT1).

The remaining parallel data is converted back to an analog signal. Two output amplifiers provide the desired output signal conditioning. The analog output is available on two output connectors. Both outputs are capable to drive 50 Ohm loads (BNC jack and SM jack). The maximum output voltage swing is +/-10V for the BNC jack and +/-5V for the SM jack.

Viplax-I receivers are equipped with a microcontroller system board which provides the control and supervision of the digital data processing. Communication with a host computer is available through a USB- or TCP/IP ethernet interface (depending on the type of the Viplax-I receiver).

The highspeed digital data processing is implemented in a field programmable gate array (FPGA), which is a custom design.

Both, the microcontroller unit and the FPGA unit are separate modules pluggable to the Viplax-I system board. The microcontroller unit is either a MiniFlex-USB module (USB version) or a ARM7TDMI embedded Linux (TCP/IP version) from FS-Forth Systems. The FPGA is a Sphinx-C100-RevA2 module. Further informations can be found in the chapters concerning the software configuration.

The receiver comes in euroboard form factor. All digital signals are connected to headers and/or 64 pin (a+c) VG type connector. The printed circuit board is installed in a 3U, 10HU plug-in case.

## Functional Description of the Error Logic

Viplax-I includes a fast error detection logic with a total response time of about 1,5 $\mu$ s (inclusive data transmission from the transmitter to the receiver). This system exists of two separate subsystems, the **error processing system** and the **first fault memory**.

### Error Processing System

Transmitter and receiver errors will be collected and processed by this instance. The error processing system is optimized and needs only several system clock cycles (about 100ns). Compared to the total response time, the error handling is almost negligible.

The description of the error system behaviour and the resulting system status is described as follows. All signals are 'active high':

- **LOW\_BAT:** This error signal is caused by the transmitter. The signal is connected to the output D\_OUT2 (connector X6, pin 7). It is also an input to the first fault memory.
- **COMP\_FLT:** This error signal is caused by the transmitter. The signal is connected to the output D\_OUT3 (connector X6, pin 6). It is also an input to the first fault memory.
- **AD\_FLT:** This error signal is caused by the transmitter. The signal is connected to the output D\_OUT4 (connector X6, pin 5). It is also an input to the first fault memory.
- **LINK\_FLT:** This signal indicates a fiber optic error. It is asserted in case of a not installed or faulty fiber optic cable. Other reasons are the damage of the optical subsystem in transmitter or receiver component. A LED on the front panel will indicate this error. Furthermore it is an input to the first fault memory and, in combination with the enable status of the microprocessor, connected as LINK\_RDY to D\_OUT5 (connector X6, pin4).
- **LINK\_RDY:** This status indicates the standby of the Viplax-I transmission system. LINK\_RDY is deasserted if a LINK\_FLT is asserted or if the microcontroller is in configuration process e.g. changing comparator thresholds to the FPGA. Right after power up or after a system reset, the signal is suppressed for about 300ms to guarantee the correct initialisation of the internal phase locked loop circuits. The signal is connected to the output D\_OUT5 (connector X6, pin 4).
- **COMP\_1L, COMP\_1H, COMP\_2L, COMP\_2H:** are the upper respective lower thresholds of the both receiver comparator units. These signals are not connected to any outputs but used as inputs to the first fault memory.

If desired, the error detection system can be disabled. However this has also an effect to the first fault memory, since these errors are not available anymore.

The only exception is the LINK\_FLT signal which is always enabled to guarantee a reliable supervision of the fiber optic line.

### Link Synchronisation

The Viplax system is with firmware 2.8 or up equipped with a link synchronisation state machine. This feature helps syncing the link during the startup sequence and works as follows:

If the Viplax system is turned on, the receiver detects the incoming data of the transmitter and



synchronizes it until a valid data connection is established. After the link is stable, the behaviour of the state machine depends on enabling the resynchronisation or not (EN\_RESYNC). If it is on (enabled), the link synchronizes every time, the data gets invalid. If the EN\_RESYNC is disabled, the synchronisation will never take place for a second time. In both cases, the link fault is unaffected of EN\_RESYNC and is stored in the first fault memory in any case. It can be cleared by clearing the faults via the maintenance software or the dedicated pin on the backplane.



Figure 12 : Viplax-I Receiver (front view).

## First Fault Memory

The First Fault Memory sub-system is responsible for storing errors. If an error occurs there might be a lot of consecutive errors as result of the initial fault. Since these consecutive errors are just a side effect the system masks them out. Only the first fault is stored.

There is one exception. The LINK\_FLT error is stored in any case. In principle it is possible that more than one error is stored in the memory if they occur exactly at the same time. The first fault memory is available until erased by the user. Erasing the first fault memory is achieved by the service software (see below) or by asserting a TTL signal to the digital input D\_IN6 (pin A25 of the 64 pin VG type connector X5). The service software allows erasing the first fault memory periodically.

The first fault memory generates the following error signals:

**COMP\_1L, COMP\_1H, COMP\_2L, COMP\_2H, LOW\_BAT, AD\_FLT, COMP\_FAULT and LINK\_FLT.**

The two last mentioned signals have a special function.

The COMP\_FAULT is a collective error of the transmitter and receiver comparator thresholds.

A fault in the fiber optics occurs right after power up sequence or after a system reset. Responsible for this behaviour are the inrush effects of the built in phase locked loops. For this reason the LINK\_FLT memory is disabled for about 300ms during power up or reset.

All memories except the LINK\_FLT can be disabled or enabled via the service software.

The memory locations are wired to the connector X5 (64 pin VG type connector) according to the following table.

<i>Signal</i>	<i>connector pin of X5</i>
LINK_FLT	A16
COMP_1L	A17
COMP_1H	A18
COMP_2L	A19
COMP_2H	A20
COMP_FAULT	A21
LOW_BAT	A22
AD_FLT	A23

Table 9: Error Signals wired to the connector X5.

Additionally the signals are wired to the 10 pin header X10 according to the following table:

<i>Signal</i>	<i>connector pin of X10</i>	<i>Signal</i>	<i>connector pin of X10</i>
COMP1_L	PIN1	COMP1_H	PIN2
COMP2_L	PIN3	COMP2_H	PIN4
LINK_FLT	PIN5	LOW_BAT	PIN6
AD_FLT	PIN7	COMP_FAULT	PIN8
GND	PIN9	GND	PIN10

Table 10: Error Signals wired to the connector X10.

## Signal LEDs

The Viplax-I receiver with USB has 7 LEDs (Figure 12). The LEDs are described as follows:

<b>LINK-FLT</b>	There is trouble with the fiber optics.
<b>STDBY</b>	The Viplax-I transmission system is in standby and ready to operate.
<b>AD-FLT</b>	The first fault was an AD_FLT .
<b>LOW-BAT</b>	The first fault was a LOW_BAT.
<b>COMP-FLT</b>	The first fault was a COMP_FLT .
<b>USB-TxD</b>	USB send signal
<b>USB-RxD</b>	USB receive signal

Table 11: Signalisation of the USB type.

The Viplax-I receiver with TCP/IP has 8 LEDs. The LEDs are described in the following table.

<b>STDBY</b>	The Viplax-I transmission system is in standby and ready to operate.
<b>LINK-FLT</b>	There is trouble with the fiber optics.
<b>AD-FLT</b>	The first fault was an AD_FLT .
<b>LOW-BAT</b>	The first fault was a LOW_BAT.
<b>COMP-FLT</b>	The first fault was a COMP_FLT .
<b>ACTIVITY</b>	There is data transfer activity in the ethernet.
<b>STATUS 1</b>	Not used so far.
<b>STATUS 2</b>	Not used so far.

Table 12: Signalisation of the TCP/IP type.

## Digital Interface

The Viplax-I receiver does not only convert the received serial data stream into an analog output signal, it also provides a parallel TTL conform digital interface for the analog data at connector X5. This option allows to do real time data processing.

The used 14bit data format is defines as:

A binary '0' („00000000000000“) represents -100% of the analog value,  
 a „10000000000000“ represents 0% and  
 a „11111111111111“ +100% of the analog value.

Additionally there is a control signal 'DA\_D\_VALID' , which indicates by its logic '1' state, that the data is valid.

The signal 'DA\_D\_VALID' is asserted only in the case that no transmitter error is detected ('AD\_FLT' or 'LOW\_BAT') and the fiber optics work fine. As soon as a 'LINK\_FLT' occurs, digital data is not valid indicated by 'DA\_D\_VALID' = 0. In this case the digital data itself will be set to „10000000000000“.

If the data processing system is disabled DA\_D\_VALID will be asserted even in the case, when there are transmitter errors detected ('AD\_FLT', 'LOW\_BAT'). The table below shows the connector

pinout for X5.

All signal are TTL compatible. The 14bit digital analog data is defined by DA\_D13 down to DA\_D0 where DA\_D13 is the most significant bit and DA\_D0 the least significant one.

<i>Connector Pin</i>	<i>Signal</i>	<i>Connector Pin</i>	<i>Signal</i>
X5-A1	DA_D13	X5-A9	DA_D5
X5-A2	DA_D12	X5-A10	DA_D4
X5-A3	DA_D11	X5-A11	DA_D3
X5-A4	DA_D10	X5-A12	DA_D2
X5-A5	DA_D9	X5-A13	DA_D1
X5-A6	DA_D8	X5-A14	DA_D0
X5-A7	DA_D7	X5-A15	DA_D_VALID
X5-A8	DA_D6		

Table 13: Digital Data wired to the connector X5.

Additionally the connector X11 is wired with the digital data and with the status information 'AD\_FLT' of the first fault memory. Table 14 shows the connector layout.

<i>Connector Pin</i>	<i>Signal</i>	<i>Connector Pin</i>	<i>Signal</i>
X11-PIN3	DA_D13	X11-PIN11	DA_D5
X11-PIN4	DA_D12	X11-PIN12	DA_D4
X11-PIN5	DA_D11	X11-PIN13	DA_D3
X11-PIN6	DA_D10	X11-PIN14	DA_D2
X11-PIN7	DA_D9	X11-PIN15	DA_D1
X11-PIN8	DA_D8	X11-PIN16	DA_D0
X11-PIN9	DA_D7	X11-PIN17	DA_D_VALID
X11-PIN10	DA_D6	X11-PIN18	AD_FLT

Table 14: Digital Interface wired to connector X11.

## Digital I/O-Ports

In the preceding chapters, most of the digital signals are explained. Mentioned but not described up to now is the RESETn which is wired to D\_OUT6 respective to the connector X6 pin number 3. The signal is also connected to the reset push button, which is located behind the small hole of the front panel and is low active. D\_OUT6 can be used to initialize peripheral components together with the Viplax-I transmission system.

A collection of all connector layouts can be found in the appendix of this document.

## Power Supply for the Receiver

The receiver requires three different voltages. Two times 15 VAC / 250mA and 9VAC / 1.4A. Inventronik GmbH has a suitable power supply in its portfolio.

The supply for the receiver can be connected to the 64 pin VG type connector or to clamps located behind the VG connector. Last mentioned are to the best advantage if the receiver shall not be mounted in a 19“ rack, but used as a stand alone component. In this case the rear panel of the plug-in unit has to be removed to gain access to the clamps. The layout of the receiver (see appendix) or Figure 11 shows the position of the clamps in detail. The connector X5 connects to the power supplies as follows:

<i>Connector Pin</i>	<i>Signal</i>
<i>X5-C1</i>	<i>15V AC I</i>
<i>X5-C2</i>	<i>15V AC I</i>
<i>X5-C16</i>	<i>9V AC</i>
<i>X5-C17</i>	<i>9V AC</i>
<i>X5-C31</i>	<i>15V AC II</i>
<i>X5-C32</i>	<i>15V AC II</i>

Table 15: Supply voltages for the receiver connected via connector X5.

## Power Up Sequence

The power up sequence of the Viplax-I transmission system is not critical. It doesn't matter in which order the transmitter and the receiver are powered on. Merely there is the effect, that the LINK\_FLT is suppressed for 300ms due to the phase locked loops as mentioned above. Is the link after 300ms not established, the LINK\_FLT can not be cleared. After clearing the faults by a reset or by the service software, the Viplax-I transmission system is ready to use.

## Maintenance of the Receiver

The Viplax-I receiver is completely maintenance free. Take care of the very sensitive fiber optics.

If the receiver is not connected to a fiber optic line, a cap should protect the optical subsystem to avoid any damage.

Do not touch the fiber optic connector at its 'Ferrule'. If Viplax-I is not used, please cover the Ferrules with dust caps.

## Maintenance of the Transmission System

The Viplax-I transmission system is nearly free of maintenance except of long term offset recalibrations. Ageing of components over the time may make this necessary. The user can independently calibrate the offset values of transmitter A/D converter and the receiver D/A converter via the system software.

## Offset Calibration

Prerequisites for the calibration of the Viplax-I transmission system is a high quality multimeter and a  $50\Omega$  BNC-terminator for the BNC type transmitter or a suitable SMB terminator with  $50\Omega$  (a SMB-short circuit connector will do it too). The calibration should be accomplished on equipment with operating temperature. An operation of one hour before starting the calibration process is recommended.

First step is connecting the multimeter (DC voltage measurement) to the receivers BNC jack. The receiver calibration is done with disconnected fiber optic, i. e. with asserted LINK\_FLT. To adjust the offset of the receiver it is necessary to start the service program. The offset calibration is very simple. The measured offset has to be minimized with the software receiver calibration buttons.

In a next step, a terminator must be installed at the transmitter and the fiber optic link has to be established. The LINK\_FLT needs to be cleared by the service software. Now the Viplax-I transmission system should be in operation condition. To minimize the offset use again the software calibration buttons, but this time for the transmitter.

Viplax-I is adjustable to a minimum offset of about 1mV. An optimal 0.0mV offset is not possible due to noise, the relative simple offset calibration equipment and also due to the finite quantisation of the AD- and DA converters.

# Viplax-I Service-Software

## Viplax-I Interface Options

There are two options to establish communication between PC and the Viplax-I receiver. The USB interface is useful if the Viplax-I receiver is nearby or if you have a notebook at your disposal. For long distance configuration we recommend the TCP/IP ethernet option. LANs are widely used and the necessary infrastructure normally allows for remote control of the Viplax-I receiver. The following sections will explain how to install the necessary device drivers and how to use the software.

### USB Option: Installing a Driver for a Virtual USB/RS232 Port

The MiniFlex-USB needs to be connected with a power supply and the USB cable, after which you will be asked to select first a USB<->Serial driver and finally the USB-Serial-Port driver. You'll find these drivers on the product-CD in the directory Windows\USB Driver.

#### Why is this driver needed?

The driver maps the USB interface on your PC to a virtual serial RS-232-C interface. Programming a RS-232-C interface is much easier than programming the USB interface because you don't have to know about complicated USB protocols and you can use many well-tested programming libraries with serial communication support. Exchanging data via USB is really easy this way.

**Please note:** the driver version on the product is not certified by Windows XP (a warning appears).



## Screenshots of the Installation Process

After connecting the MiniFlex-USB to your PC, a dialog window opens (see figure 4).

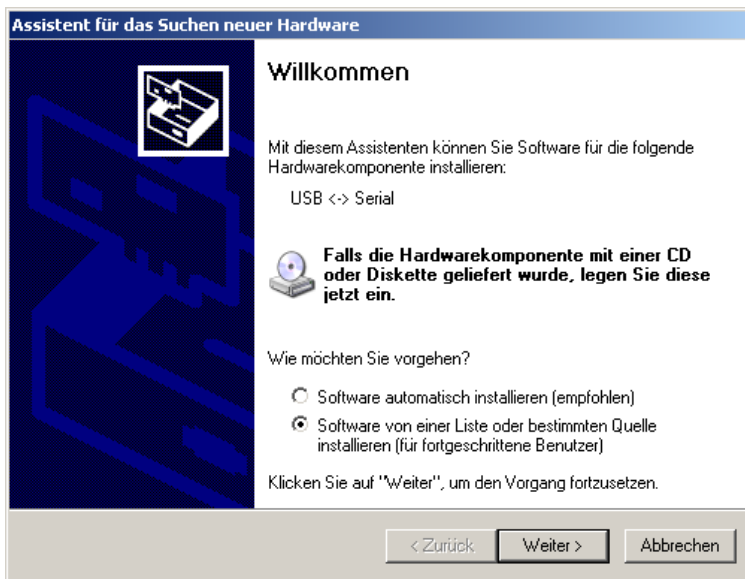

Figure 13: Windows hardware facility assistant

Don't use automatic installation here.

Please use the second option in the dialog window to allow selection of the appropriate directory. Press ---

WEITER--- to continue.

The following dialog appears:

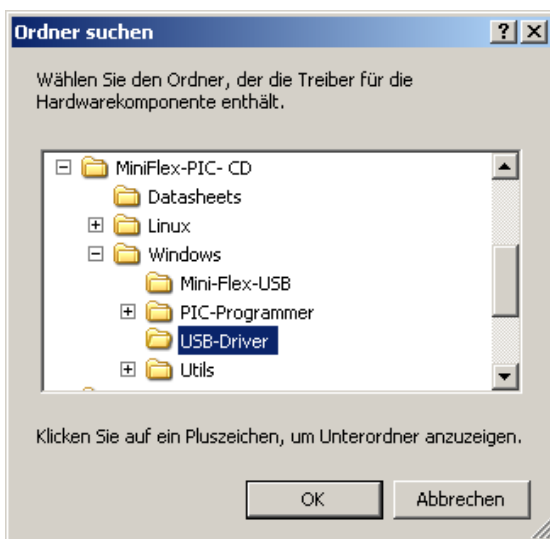

Figure 14: Selection of the driver directory

Please choose the location of the driver. You will find it on the product-CD in the folder (Windows\USB Driver). The installation procedure ends with the last dialog window. This will be the the „USB Serial Port“ installation. After that the virtual serial COM is ready for use.

PCs are normally equipped with multiple COM-ports so the virtual COM-port is not mapped to a specific port number (e.g. COM3). Windows has its own scheme for the distribution of virtual port numbers. How to find the right COM port is discussed later in this documentation.



Figure 15: Finish the driver installation; Serial converter

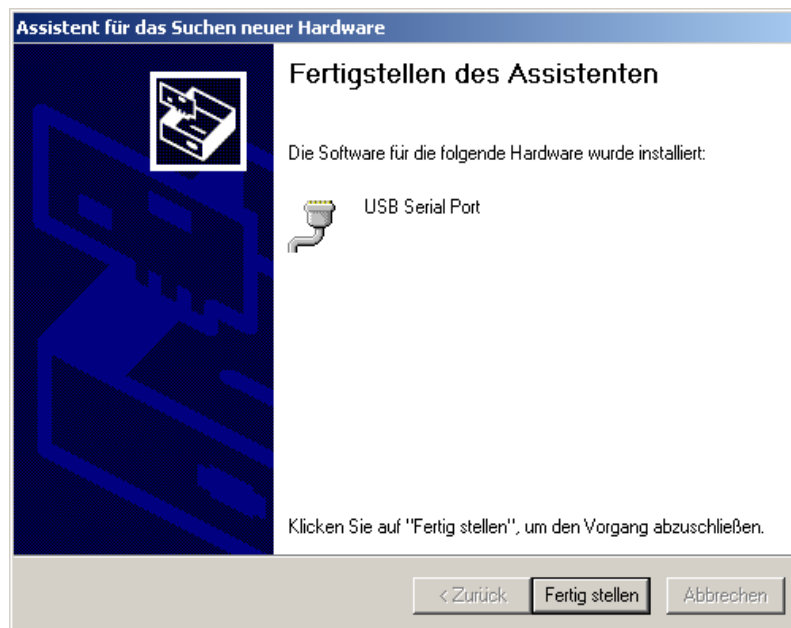

Figure 16: Finish the driver installation; USB serial port driver

## Verifying the COM-Ports

Next you should find out which COM-port is used for the virtual serial interface. The COM-port in use depends on the number of COM-ports already available in your PC. To figure it out you'll have to open the device manager (system/hardware) and open connectors (COM and LPT). The USB Serial Port shows up (here COM4 is used for the USB Serial Port).

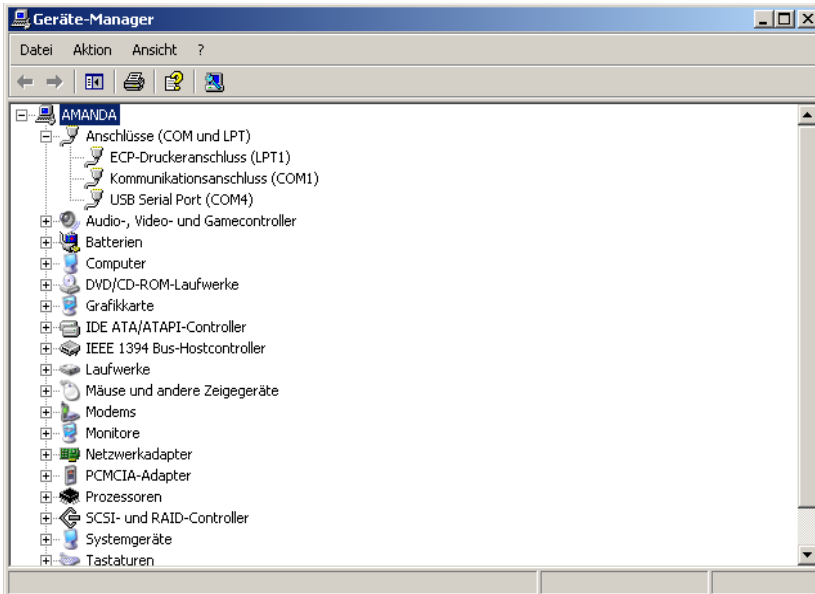

Figure 17: USB Serial Port (COMx)

## Viplax-I Configuration Program

For the Windows 2000/XP™ operating system we offer an easy to use configuration program. All adjustments are spread over a tabbed form. The following screenshot shows what can be done.

1. ---*PROPERTIES*--- Choose a serial port:

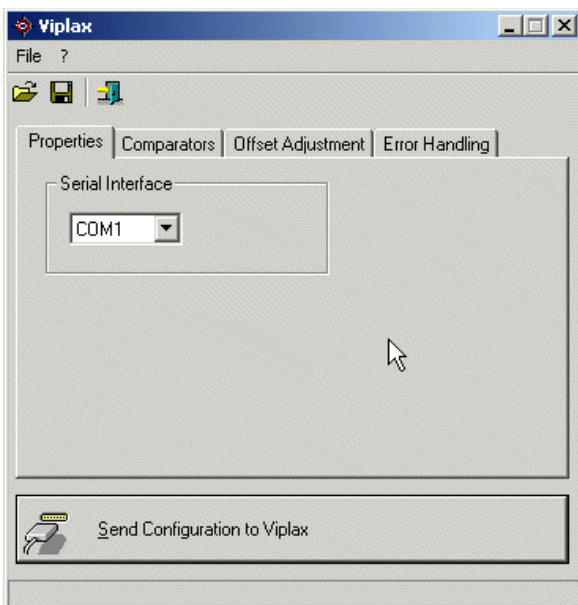

Figure 18: Viplax-I configuration program, serial interface

In this dialog form choose the virtual serial interface which you previously found to correspond with the used USB-port. Changes to the Viplax-I settings will not be transferred to the Viplax-I system until you click to the |---*SEND CONFIGURATION TO VIPLAXONFIGURATION*---| button.

2. ---COMPARATORS--- Adjustments to the threshold comparators:

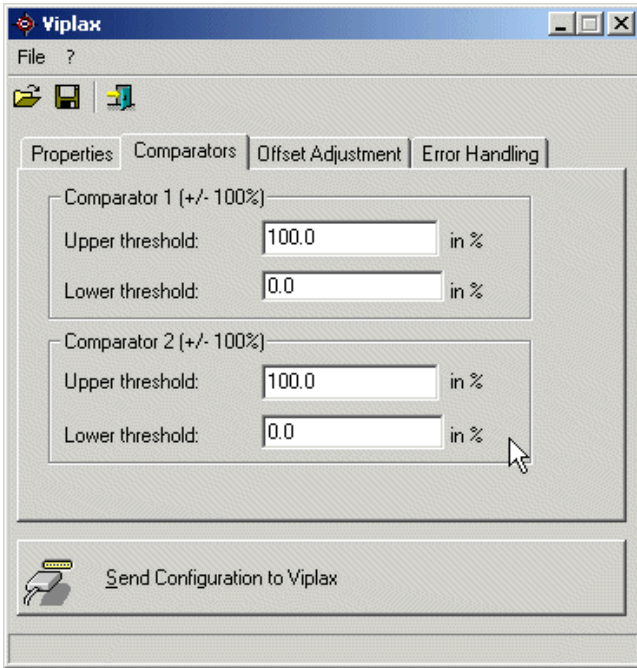

Figure 19: Viplax-I configuration program, thresholds

Input values are percentage values. Since we have a bipolar voltage input we extended the range and allow -100% to 100% values. Values in the range from 0% to 100% define a positive input threshold, -100% to 0% a negative one. The threshold comparator triggers an error if the input voltage falls below or raises above the adjusted thresholds.

3. ---Comperators--- Adjustments for the 2<sup>nd</sup> threshold comparator: (see above)

4. ---ERROR HANDLING---:

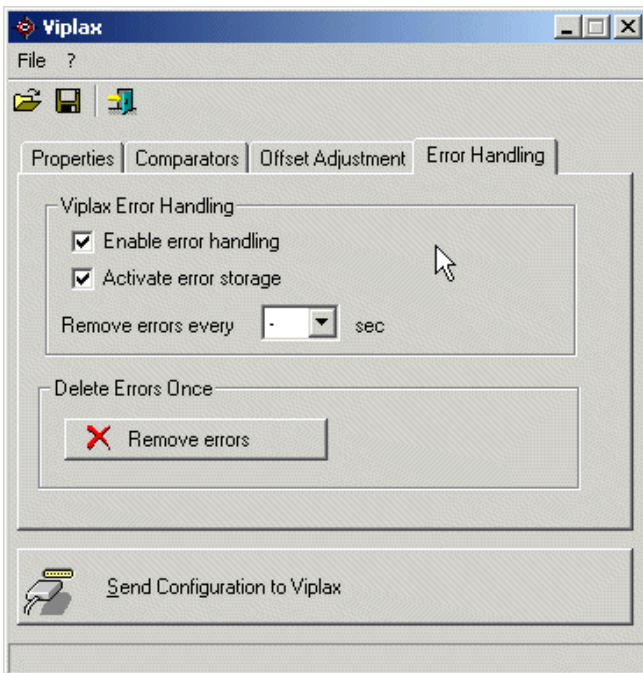

Figure 20: Viplax-I configuration program, error handling

The first checkbox enables or disables the general error handling.  
 The second one activates the first-fault-memory option.  
 If you want to erase upcoming errors in certain time cycles, you might use the cyclic error erase function ---REMOVE ERRORS EVERY X SEC--- '-' **disables** the cyclic error erase function.  
 The red error erase button ---REMOVE ERRORS--- erases an error once.

5. ---*OFFSET ADJUSTMENTS*---

The offset adjustment can be done separately for the Viplax-I sender and receiver.

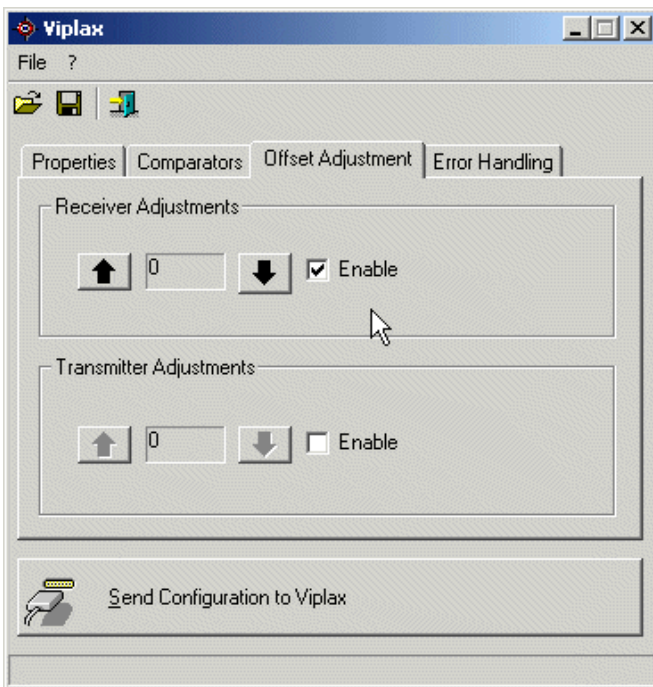

Figure 21:Viplax-I configuration program, offset adjustments

Each offset setting can take values between -127 and 128.

To change an offset value you have to enable the settings and use the up and down arrows. Normally it only takes small values to accomplish a satisfying offset calibration.

**Please note:** Using the ---*SEND CONFIGURATION TO VIPLAX*--- button is not necessary for the offset calibration! (See also Offset Calibration)

---*SEND CONFIGURATION TO VIPLAX*---

This button sends all adjustments to the Viplax-I receiver. If there is a problem with the serial port or if Viplax-I doesn't answer correctly you will get an error message.

If you need to integrate these Viplax-I functions into your own program, please let us know. We can provide information about the used protocol. All commands are in simple ASCII form.

## TCP/IP Ethernet-Interface: Using a Web-Browser for Viplax-I Configuration

### Overview

A web server on the embedded Linux system in the Viplax-I receiver allows you to use a browser to adjust the various settings of Viplax-I. CGI-scripts provide basic authentication and allow easy configuration of the whole system.

### Getting started

Before you power-on Viplax-I, you must establish a connection to your local network. A DHCP server is mandatory for the first start-up. This guarantees that Viplax-I can retrieve a valid IP address. Next you will need to know the assigned IP address to be able to make adjustments to your configuration with a web browser.

Resolving the IP address can be solved in different ways. One possibility is to log the boot process with a serial RS-232-C monitor program on Viplaxs RS-232-C port. Use the Null-Modem-Cable (part of the Viplax-I shipping) to connect your PC with the Viplax-I serial port. Now, you have to start a monitor program. For Win32/XP you could use *HYPERTERM* which is part of Windows™. If you use Linux/Unix you might find *MINICOM* or *SEYON* helpful to monitor the boot messages. Please read also the man pages to those programs.

The serial port settings are as follows:

- Baudrate: 38400
- Databits: 8
- Stopbits: 1
- Parity: none

After a reset or after connecting Viplax-I to the power supply, you will get the following messages in your terminal program:

```
LxNETES Bootloader $Revision: 1.19 $  
  
ABCDEFGHIHO@00001618  
  
Bootstrap: 03ff  
...
```

after awhile the boot process stops and you will see a command line input prompt '#' (hash).

```
#
```

Now, if you scroll up the hyperterm output a bit, you will see following lines:

```
Sending DHCP requests ., OK
```

```
IP-Config: Got DHCP answer from DHCP-SERVER-ADDRESS, my address is  
Viplax-IP-ADDRESS
```

*Viplax-IP-ADDRESS* is the IP address you will need to access the web frontend. Now open your favourite web browser and enter as URI: `http://Viplax-IP-ADDRESS`.

In our case we would type `http://192.168.1.53`

If you have administrator privileges on the DHCP server, you could look in the DHCP-log-files to figure out the assigned IP address, or if you are connected to a small local area network you might use *NMAP* to scan your network for new network devices. If nmap detects a device from FS-Forth it might be Viplax-I!

## Viplax-I Start Page

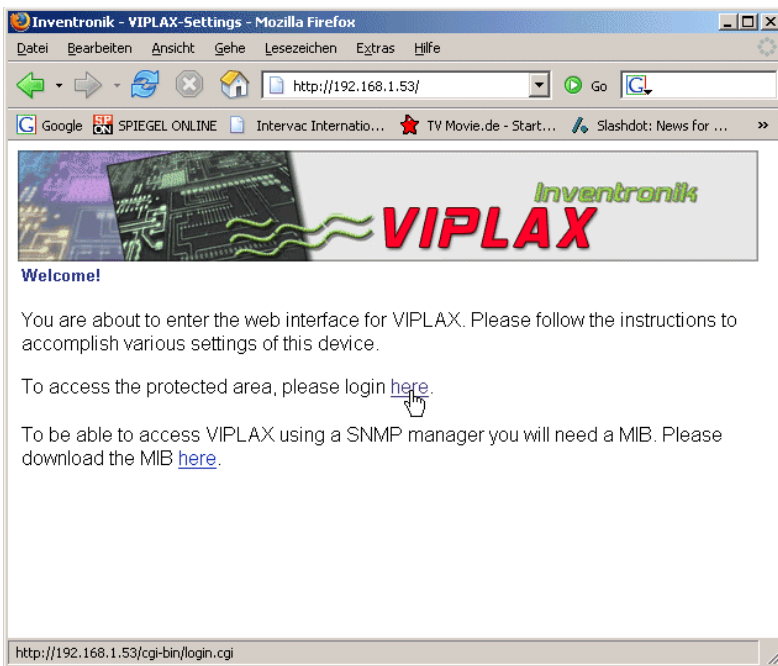

Please use your favourite web-browser and follow the link *HERE* to be forwarded to the authentication page.

Figure 22: Welcome-Screen



## Viplax-I Login (HTTP-Authentication)

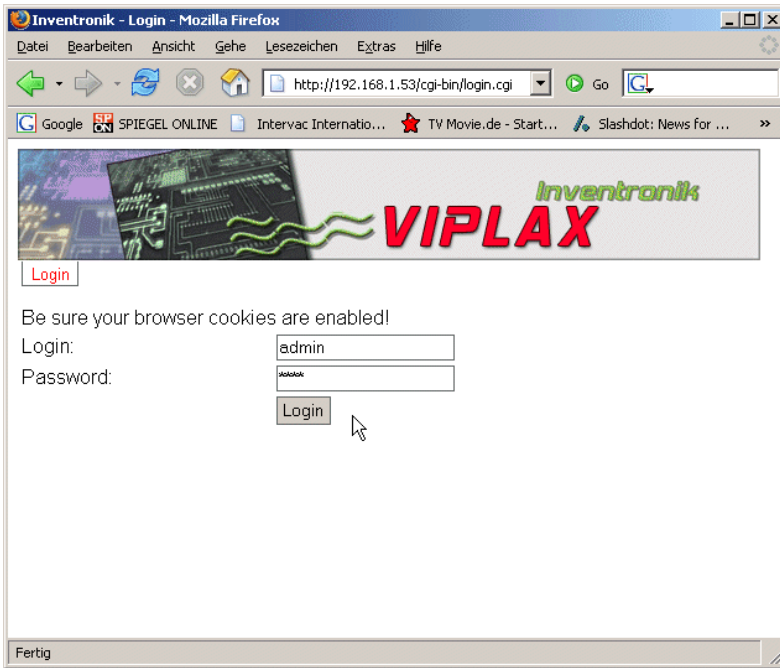

Figure 23: User Authentication

All Viplax-I functions are protected through authentication. You must login to be able to make any changes. To login successfully your browser cookies must be turned on!

First-time login is „**admin**“ and „**1234**“ is the default password. It is a good idea to change the password immediately after you have successfully logged-in.

If you can't login please confirm that your browser is accepting cookies.

## Viplax-I Specific Adjustments

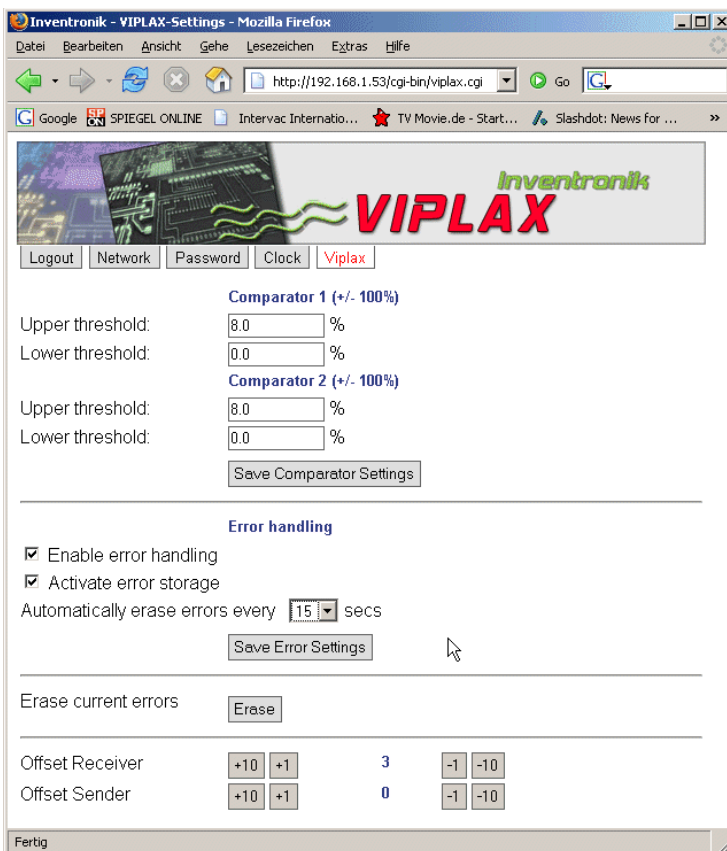

Figure 24: Viplax-I Adjustments

This figure shows all possible Viplax-I adjustments, which we have explained in detail in earlier sections of this manual.

- Adjusting the thresholds (see also ---Comparators--- Adjustments to the threshold comparators)
- Error handling (see also ---Error Handling---
- Erase current errors.
- Offset adjustment (see also Offset Calibration)



## Change Password

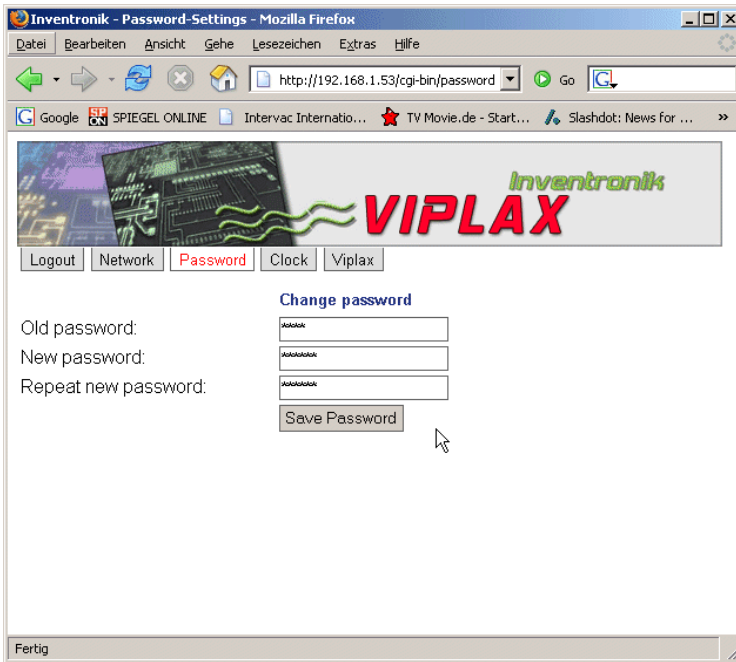

The screenshot shows a Mozilla Firefox browser window titled "Inventronik - Password-Settings - Mozilla Firefox". The address bar displays "http://192.168.1.53/cgi-bin/password". The browser's menu bar includes "Datei", "Bearbeiten", "Ansicht", "Gehe", "Lesezeichen", "Extras", and "Hilfe". The browser's toolbar shows navigation buttons and a search bar. The browser's status bar at the bottom displays "Fertig".

The main content area of the browser shows the "Inventronik VIPLAX" logo at the top. Below the logo is a navigation menu with buttons for "Logout", "Network", "Password", "Clock", and "Viplax". The "Password" button is highlighted in red. Below the navigation menu is the "Change password" form, which includes the following fields and buttons:

- Old password:
- New password:
- Repeat new password:
- Save Password

Figure 25:Change password

Not much to explain on this page!  
Anyhow, for security reasons it is necessary to type in your old password, then your new one and repeat.

In case you have forgotten your password, please email us and we will provide instructions on how to reset the password.

## Network Settings

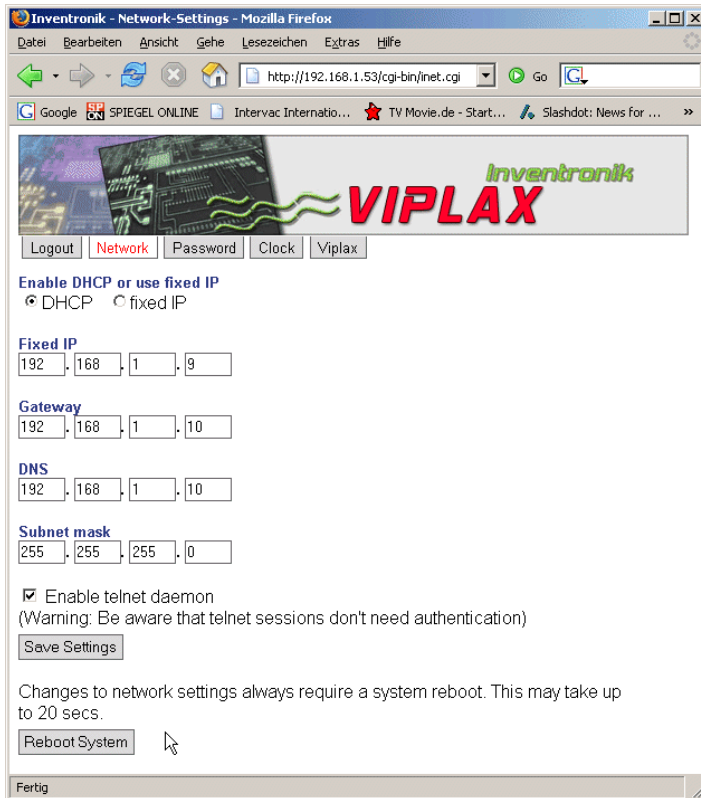

Figure 26: Viplax-I Network settings

Network integration with Viplax-I is easy. All adjustments can be made using the settings you see in the above screenshot. Predefined is the usage of a DHCP server. As mentioned earlier, to get things going, you need to have DHCP on the first time you boot your new Viplax-I. We recommend using a fixed IP address afterwards to avoid the Worst Case Scenerio or waiting for an unresponsive DHCP server (disconnected cable, unreachable DHCP server etc.)

**Worst Case Scenerio:** the DHCP server never answers and Viplax-I stays in an endless-loop stubbornly refusing start any services. Using a fixed IP avoids this!

The settings Gateway and DNS are not currently in use.

The telnet server enables remote sessions via TCP/IP. Once connected through a telnet client the user can reset some settings (e.g. passwords etc.). If you wish to use telnet please contact Inventronik GmbH. Do not use this option if you do not intend to access the system via telnet!

**Please note:** telnet sessions do not have authentication!

After changing any of the above settings, you must reboot the Viplax-I Linux system.

## TCP/IP Protocol SNMP (Simple Network Management Protocol)

SNMP is widely used in a TCP/IP network, mostly for controlling of communication equipment. Since Viplax-I can be considered as a network device, we offer a SNMP interface to control Viplax-I.

Despite the fact that SNMP says it is a simple protocol, it is not easy to understand. We highly recommend that you checkout our link section for further readings.

### Presumptions

SNMP applications are build as typical client/server applications. The client, also called Manager, is located on the controlling PC. The server, also called Agent, is ready to use on the Viplax-I-Receiver.

To be able to instantiate a communication path between manager and agent, you will need some basic programs on the controlling PC.

In our case we used the open source NET-SNMP (see <http://net-snmp.org>). The Viplax-I SNMP-agent uses the same software in version 5.2.1.

Viplax-I uses SNMP-Protocol V2 (but V3 should work too, but we did not test this).

### Installation (for Linux/Unix)

NET-SNMP is easy to install. Just use the classic `./configure - make - make install` commands to execute configuration, compiling and installing of the software package. Anyhow, if you don't want to use Linux/Unix, there are also ports for Win32 or MacOS-X, but we did not try that. After installing the software you are in need of an additional MIB-file (Management Information Base), that defines the Viplax-I agent functions. This VIPLAX-MIB ca be obtained from the Viplax-I Web-Homepage (<http://viplax-ip-address>).

Before you are able to play with SNMP you have to copy this file (VIPLAX-MIB.txt) to the MIB directory onto your PC. If you have chosen a standard installation of NET-SNMP you have to use the directory `/usr/local/share/snmp/mibs`. This directory contains all known SNMP-MIBs from NET-SNMP.

### SNMP at a glance

For the first test we do not need Viplax-I yet. Instead we will scan the structure of the previously installed Viplax-MIB. Please use the shell command:

```
snmptranslate -Tp -IR -m ALL inventronik
```

and you should see something like:

```

+--inventronik(22237)
|
+--viplaxSnmplib(1)
|
+--vsMIBComparators(1)
| |
| +-- -RW- Integer32 upperThresholdComp1(1)
| |   Range: -100..100
| +-- -RW- Integer32 lowerThresholdComp1(2)
| |   Range: -100..100
| +-- -RW- Integer32 upperThresholdComp2(3)
| |   Range: -100..100
| +-- -RW- Integer32 lowerThresholdComp2(4)
|   Range: -100..100
|
+--vsMIBErrorHandling(2)
| |
| +-- -RW- EnumVal  enableErrorHandling(1)
| |   Values: enabled(1), disabled(2)
| +-- -RW- EnumVal  activateErrorStorage(2)
| |   Values: enabled(1), disabled(2)
| +-- -RW- Integer32 eraseErrorsPeriodically(3)
| |   Range: 1..90
| +-- -RW- Integer32 eraseErrorsOnce(4)
|   Range: 1
|
+--vsMIBErrorCounters(3)
|
+-- -RW- Integer32 totalErrorsUpperComp1(1)
+-- -RW- Integer32 totalErrorsLowerComp1(2)
+-- -RW- Integer32 totalErrorsUpperComp2(3)
+-- -RW- Integer32 totalErrorsLowerComp2(4)

```

The branches vsMIBComparators and vsMIBErrorHandling carry the basic Viplax-I parameters. We will show you how to read and write these parameters later. New, and exclusive to SNMP are 4 parameters in the branch vsMIBErrorCounters. These registers count for each threshold separately the oversteps. You can reset the registers anytime you want. After a new start of Viplax-I these registers have a zero value.

## Read Viplax-I parameters

If you want to read back a Viplax-I parameter you will need the following command:

```
snmpget -m ALL -c viplax-ro -v 2c <ip-addr> VIPLAX-MIB::
```

The read-only password is "viplax-ro", <ip-addr> is the IP address of the agent (Viplax-I) and <Regname> is the name of a leaf from Viplax-I MIB-structure, for example upperThresholdComp1. The trailing ".0" says that the value is a scalar type.

If you want to read all Viplax-I parameters at once, than you execute a snmpwalk command, here for example:

```
snmpwalk -m ALL -c viplax-ro -v 2c 192.168.1.52 inventronik
```

## Change Viplax-I parameters

This is as easy as reading a Viplax-I parameter. The following command will write a new value into the Viplax-I register.

```
snmpset -m ALL -c vplx9u1o1 -v 2c <ip-addr> VIPLAX-MIB::
```

"vplx9u1o1" is the read-write password.

Unfortunately this password can't be changed; it is part of the ROM configuration. Later on we will support SNMP.V3 which will encrypt the password before it is sent over the network. After that we will add support for changeable password storage.

The command parameter "i" in the above command says that the value is an integer (Float values are not explicitly supported by SNMP). <Value> is the integer value of the Viplax-I parameter.

**One important remark regarding eraseErrorsOnce:** If you want to delete an error, you must write a zero value into the register. Reading a value different than zero means there has been an error triggered.

## What's Next (To do):

We plan to extent the SNMP functionality and we will add trap support. Which traps we will covered has to be defined. Possibilities are:

- Authentication Trap: Wrong SNMP or HTTP password entered.
- Error Trap: As soon as an error has been triggered (probably in different classes).
- *Suggestions are welcome!*

**Links:**

- <http://www.net-snmp.org> – a lot about SNMP
- <http://www.net-snmp.org/tutorial/tutorial-5/toolkit/mfd/> - MIB for Dummies
- [http://www.enseirb.fr/~kadionik/embedded/snmp/english/net-snmp\\_english.html](http://www.enseirb.fr/~kadionik/embedded/snmp/english/net-snmp_english.html) - SNMP for embedded Applications (very clear and easy to understand)

## **Changing the FPGA-Configware**

Under normal circumstances it is not necessary to change the FPGA content of the Viplax-I receiver or sender. However, for exceptions to the rule, it might come in handy if there are minor changes.

The receiver contains the FPGA module 'Sphinx-C100-Rev.A' also produced by Inventronik GmbH. On our website, we provide a detailed documentation that explains the necessary steps to configure the FPGA. Programming must take place over the 'Active Serial' connector. The JTAG interface is not used.

The transmitter does not contain a 'Sphinx-C100-Rev.A' module, but the programming remains the same. The unused JTAG interface has been removed.

## **Changing the Microcontroller Firmware (MiniFlex only)**

Again, under normal circumstances there is no need to change the firmware. In the interests of software flexibility there is a possibility to make adjustments to the firmware to meet special requirements in industrial and scientific applications. Please contact us with your specifications.

The USB version of the Viplax-I receiver uses the 'MiniFlex-USB' developed by Inventronik GmbH. The documentation in the download area of our website explains how to program the controller.

## **Software Support**

Inventronik GmbH offers development services to extend or expand the functionality of Viplax-I. Please contact us if you have further questions.

# Appendix

## Technical Data

### Transmitter\_V3\_RevA, Receiver\_V3\_RevA:

#### *Input Amplifier:*

Input voltage range:  $\pm 0.25\text{V}$ ;  $\pm 1.0\text{V}$ ;  $\pm 2.5\text{V}$ ;  $\pm 4.0\text{V}$ ;  $\pm 10.0\text{V}$ .

Voltage Gain: 32dB; 20dB; 12dB; 8dB; 0dB (adjustable).

#### *Anti-Aliasing-Filter:*

Bessel Low Pass Filter 4th Order:

3dB Frequency: 2.5MHz

Voltage Drop near the 3dB Frequency: 20dB/Octave.

**Remark:** The theoretical voltage drop of 24dB is not reached due to the not ideal but nevertheless accurate behavior of the installed operational amplifiers.

#### *A/D-Wandler:*

Resolution: 14 bit.

Samplingrate: 10Mbps.

Signal to Noise Ratio: >65 dB.

Integral Linearity Error:  $\pm 2.5$  LSB.

Differential Nonlinearity:  $\pm 1$  LSB.

**Further information:** see the Analog Devices AD9240 data sheet.

#### *Digitale Signal Processing:*

Signal Latency:  $< 2.5\mu\text{s}$

System Bandwidth: 2.5MHz

Window Comparators: bipolar, adjustable.

System Status Bits: A/D-Overflow; Battery Load Condition, System Error, Comparator Thresholds.

Digital Inputs: 5 Pin (Transmitter), 7 Pin (Receiver).

Digital Outputs: 5 Pin (Transmitter), 7 Pin (Receiver).

Output voltage levels: 5V at the VG type connector, 3.3V at the pin headers.

Current: 10mA.

Input voltage levels: TTL tolerant.

Visualisation: All relevant System Status Bits via LEDs.

#### *Fiber Optics:*

Maximum Bit Stream Frequency: 200 Mbit.

Optical Wave Length: 1300nm.

Fiber Type: 50 $\mu\text{m}$  oder 62.5 $\mu\text{m}$  core, multimode.

Connector: ST Type.

Maximum Length: 1000m. (the maximum achievable length is dependant on the quality and condition of the fiber optic cable.)



User definable Gains: 1.176 (Stellung SJ3: 2-3; Stellung SJ4: x1.176;  $U_{inmax} = 2.126V$ )  
0.294 (Stellung SJ3: 1-2; Stellung SJ4: x1.176;  $U_{inmax} = 8.503V$ )

*D/A converter:*

Resolution: 14 bit.  
Sampling Rate: 125Mbps.  
Spurious Free Dynamic Range: >75dB.  
Integral Linearity Error:  $\pm 4.5$  LSB.  
Differential Nonlinearity:  $\pm 1.5$  LSB (typ).

**Further information:** see the Analog Devices AD9764 data sheet.

*Output Amplifier (Twin Amplifier):*

Output Voltage Range:  $\pm 10.0V$  (BNC),  $\pm 10.0V$  (SMB), (full conduction).  
Output Impedance: 50 Ohm.

*Voltage Supply:*

Transmitter: 12 VAC / 1.2A.  
Receiver: 15VAC / 0.25A; 15 VAC / 0.25A; 9VAC / 1.4A.

**As mentioned above: we do not recommend the use of switched mode power supplies!**

## Connector Pinouts

<i>Signal</i>	<i>Connector Pin</i>	<i>Signal</i>	<i>Connector Pin</i>
GND	PIN1	GND	PIN2
RA5 (not used)	PIN3	RA0 (not used)	PIN4
RA4 (not used)	PIN5	RA1 (not used)	PIN6
RA3 (not used)	PIN7	RA2 (not used)	PIN8
+5V	PIN9	+5V	PIN10

Table 16: Connector SV1; Receiver.

<i>Signal</i>	<i>Connector Pin</i>	<i>Signal</i>	<i>Connector Pin</i>
GND	PIN1	GND	PIN2
RC5 (not used)	PIN3	RC0 (not used)	PIN4
STDP (not used)	PIN5	RC1 (not used)	PIN6
not connected	PIN7	RC2 (not used)	PIN8
+5V	PIN9	+5V	PIN10

Table 17: Connector SV2; Receiver.

<i>Connector Pin</i>	<i>Signal</i>	<i>Connector Pin</i>	<i>Signal</i>
X5-A1	DA_D13	X5-C1	15V AC I
X5-A2	DA_D12	X5-C2	15V AC I
X5-A3	DA_D11	X5-C3	GND
X5-A4	DA_D10	X5-C4	GND
X5-A5	DA_D9	X5-C5	GND
X5-A6	DA_D8	X5-C6	GND
X5-A7	DA_D7	X5-C7	GND
X5-A8	DA_D6	X5-C8	GND
X5-A9	DA_D5	X5-C9	GND
X5-A10	DA_D4	X5-C10	GND
X5-A11	DA_D3	X5-C11	GND
X5-A12	DA_D2	X5-C12	GND
X5-A13	DA_D1	X5-C13	GND
X5-A14	DA_D0	X5-C14	GND
X5-A15	DA_D_VALID (Memory)	X5-C15	GND
X5-A16	LINK_FLT (Memory)	X5-C16	9V AC
X5-A17	COMP_1L (Memory)	X5-C17	9V AC
X5-A18	COMP_1H (Memory)	X5-C18	GND
X5-A19	COMP_2L (Memory)	X5-C19	GND
X5-A20	COMP_2H (Memory)	X5-C20	GND
X5-A21	COMP_FAULT (Memory)	X5-C21	GND
X5-A22	LOW_BAT (Memory)	X5-C22	GND
X5-A23	AD_FLT	X5-C23	GND
X5-A24	D_OUT6 (RESETn)	X5-C24	GND
X5-A25	D_IN6 (clear fault memory)	X5-C25	GND
X5-A26	D_IN5 (not used)	X5-C26	GND
X5-A27	D_IN4 (not used)	X5-C27	GND
X5-A28	D_IN3 (not used)	X5-C28	GND
X5-A29	D_IN2 (not used)	X5-C29	GND
X5-A30	D_IN1 (not used)	X5-C30	GND
X5-A31	FLAG1 (not used)	X5-C31	15V AC II
X5-A32	FLAG2 (not used)	X5-C32	15V AC II

Table 18: Connector X5; Receiver.

<i>Signal</i>	<i>Connector Pin</i>	<i>Signal</i>	<i>Connector Pin</i>
+5V	PIN1	+5V	PIN2
D_OUT6 (RESETn)	PIN3	D_OUT5 (LINK_RDY)	PIN4
D_OUT4 (AD_FLT)	PIN5	D_OUT3 (COMP_FLT)	PIN6
D_OUT2 (LOW_BAT)	PIN7	D_OUT1 (GB_BIT7)	PIN8
GND	PIN9	GND	PIN10

Table 19: Connector X6; Receiver.

<i>Signal</i>	<i>Connector Pin</i>	<i>Signal</i>	<i>Connector Pin</i>
+5V	PIN1	+5V	PIN2
D_IN6 (not used)	PIN3	D_IN5 (not used)	PIN4
D_IN4 (not used)	PIN5	D_IN3 (not used)	PIN6
D_IN2 (not used)	PIN7	D_IN1 (not used)	PIN8
GND	PIN9	GND	PIN10

Table 20: Connector X7; Receiver.

<i>Signal</i>	<i>Connector Pin</i>	<i>Signal</i>	<i>Connector Pin</i>
COMP1_L	PIN1	COMP1_H	PIN2
COMP2_L	PIN3	COMP2_H	PIN4
LINK_FLT	PIN5	LOW_BAT	PIN6
AD_FLT	PIN7	COMP_FAULT	PIN8
GND	PIN9	GND	PIN10

Table 21: Connector X10; Receiver.

<i>Connector Pin</i>	<i>Signal</i>	<i>Connector Pin</i>	<i>Signal</i>
X11-PIN1	+5V	X11-PIN11	DA_D5
X11-PIN2	+5V	X11-PIN12	DA_D4
X11-PIN3	DA_D13	X11-PIN13	DA_D3
X11-PIN4	DA_D12	X11-PIN14	DA_D2
X11-PIN5	DA_D11	X11-PIN15	DA_D1
X11-PIN6	DA_D10	X11-PIN16	DA_D0
X11-PIN7	DA_D9	X11-PIN17	DA_D_VALID
X11-PIN8	DA_D8	X11-PIN18	AD_FLT
X11-PIN9	DA_D7	X11-PIN19	GND
X11-PIN10	DA_D6	X11-PIN20	GND

Table 22: Connector X11; Receiver.

<i>Signal</i>	<i>Connector Pin</i>	<i>Signal</i>	<i>Connector Pin</i>
I/O (not used)	PIN1	GND	PIN2
I/O (not used)	PIN3	I/O (not used)	PIN4
I/O (not used)	PIN5	I/O (not used)	PIN6
I/O (not used)	PIN7	I/O (not used)	PIN8
I/O (not used)	PIN9	3,3V	PIN10

Table 23: Connector SV2; Transmitter.

## **Test Procedure for Transmitter and Receiver**

To guarantee a high product quality for every Viplax-I transmitter/receiver we've tested them thoroughly. An additional burn-in phase should avoid early failures. The test procedure is written down in a test protocol and is accomplished in three steps: the transmitter-, the receiver- and the system-test (operating one transmitter in connection with one receiver).

Remark: Viplax-I Version I-II were sold and tested in pairs to increase accuracy. However Inventronik GmbH was able to increase overall accuracy of the Viplax-I line. Due to this we've abandoned pairwise testing.

### **Transmitter Functional Tests:**

- Basic functions (JTAG programming, voltage tests)
- Comparator functionality
- Error system
- Visualisation
- Amplifier functionality

### **Receiver Functional Tests:**

- Basic functions (JTAG programming, voltage tests)
- Comparator functionality
- Error system
- Visualisation
- Test of the output amplifier
- Test of the USB/Ethernet configuration interface
- Test of the RS-232 interface (if available)
- Digital inputs and digital outputs.

During the tests the absolute accuracy of the gain is adjusted, and the components are operated over 48 hours (burn-in test).

## **Printed circuit diagrams**

All our customers who bought Viplax-I components, are able to request schematics of the purchased Viplax-I components.

## Accessories

### Receiver Power Supply

The Viplax-I receiver requires three supply voltages. 9V-AC and two times 15V-AC. Inventronik GmbH delivers a power supply which is designed for this purpose (Figure 28). The power supply delivers 9V with a current of 2,78A and 15V with each 0,83A. The power is sufficient to operate two Viplax-I receivers with one power supply. The supply is designed for mains of 230V. Other versions are available on request. The form factor is provided for installation in 19" subracks. The sizes are 3U and 14HU.



Figure 28:



Figure 27:

Figure 27 shows the rear panel of the power supply. The connector is a DIN41612 version H15. The pinout is shown in the following table:

<i>Signal</i>	<i>Connector Pin</i>	<i>Signal</i>	<i>Connector Pin</i>
9V-AC_1	Z4 and D6	N	Z28
9V-AC_2	Z8 and D10	L	D30
15V-AC-I_1	Z16	PE	Z32
15V-AC-I_2	D18		
15V-AC-II_1	Z20	no used	Z12, Z24, D14
15V-AC-II_2	D22	no Pin	D26

Table 24: Pinout of the power supply connector.

The 9V supply voltage has two pins for each pole. The first 15V voltage source is connected to Z16 and D18 and the second one to Z20 and D22.

The mains (230V-AC) are connected to the pins Z28 (Null), D30 (Phase) and Z32 (Protection Earth). Due to safety reasons, the pin D26 is removed.

**Attention: the pins Z28 and D30 may not be interchanged!**



On the front panel of the power supply are four LEDs. Three (green) indicate the correct operation of the three voltages ('15V-AC-II', '15V-AC-I' und '9V-AC') and the fourth one (red) is used for the supervision of the fuse. In normal operation the green LEDs are 'on' and the red one is 'off'. If the fuse is blown, the red LED is 'on'.

**Hint:** If the power supplies are connected to a weak load, the red LED may shine a little bit even if the fuse is ok. This is due to leakage current of the fuse fault circuit and does not indicate a malfunction of the power supply.

A defective fuse must be exchanged with the correct value of 2AT. The fuse form factor is (4x20mm), glass tube type.

## Backplane Basic and Basic-Bi

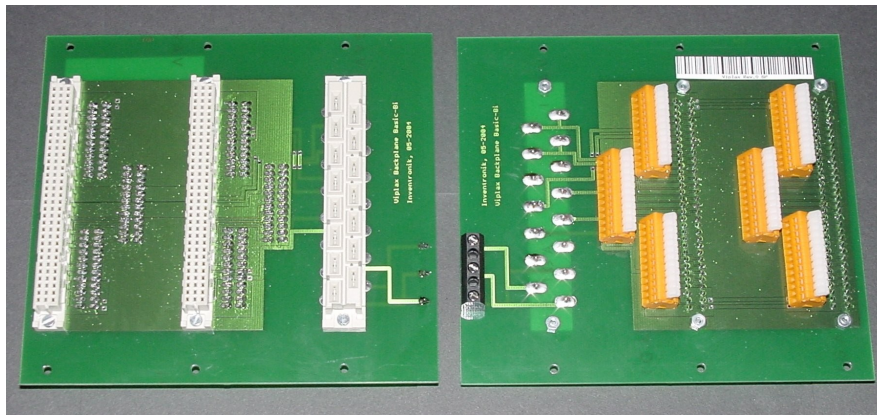

Figure 29: Front- und Rear-view of the Backplane Basic-Bi

Wiring one or two Viplax-I receivers with one receiver power supply, Inventronik GmbH offers two different backplanes. They are designed for the use in 19" subracks. The version **Backplane Basic** connects one Viplax-I receiver with a power supply and the **Backplane Basic-Bi** is built to assemble two receivers to one power supply.

The backplanes are mounted directly to 19" subracks with small auxiliary parts (distances of 3mm) but without "Z-Schienen". This construction supports isolation of the mains potential from the normally to earth ground connected subrack. To ease the installation, the backplane is marked on the front side with *TOP*. Mounted, the Viplax-I receivers are located to the left of the power supply.

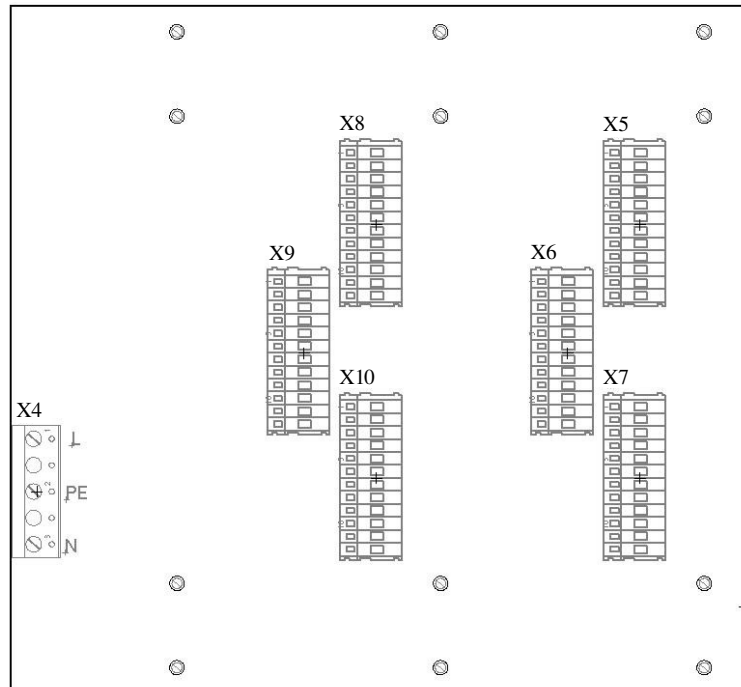

Figure 30: Backplane Basic-Bi rear view

On the rear side there are four terminals for the Backplane Basic and 7 terminals for the Basic-Bi. The small one (X4) is wired to the mains. The pinout is shown in Figure 30.

**Important:** The pin-out of the mains connector has to be done as follows:

- L = Phase
- PE = Protection Earth
- N = Null.

**Interchanging this pin-out is not only dangerous, it can destroy the Viplax-I receivers or the power supply.**

The terminals X5 to X10 carry the digital inputs and outputs of the Viplax-I receivers. The pin-outs of these terminals are shown in the printed circuit diagram for the Backplane Basic-Bi on the next page. For the Backplane Basic the terminals X1, X5, X6 and X7 are missing. The orientation of the connectors are shown in the printed circuit board as top and bottom. This is equivalent to the orientation in Figure 29. In the following table there is a summary of all connector pin-outs (X5 / X8; X6 / X9; X7 / X10).

<i>Pin X6/8</i>	<i>Signal</i>	<i>Pin X7/9</i>	<i>Signal</i>	<i>Pin X8/10</i>	<i>Signal</i>
1 (top)	A1	1 (top)	A13	1 (top)	A25
2	A2	2	A14	2	A26
3	A3	3	A15	3	A27
4	A4	4	A16	4	A28
5	A5	5	A17	5	A29
6	A6	6	A18	6	A30
7	A7	7	A19	7	A31
8	A8	8	A20	8	A32
9	A9	9	A21	9	GND
10	A10	10	A22	10	GND
11	A11	11	A23	11	GND
12 (bottom)	A12	12 (bottom)	A24	12 (bottom)	GND

Table 25: Pin-out of the Terminals X5 to X10 of the Backplane.

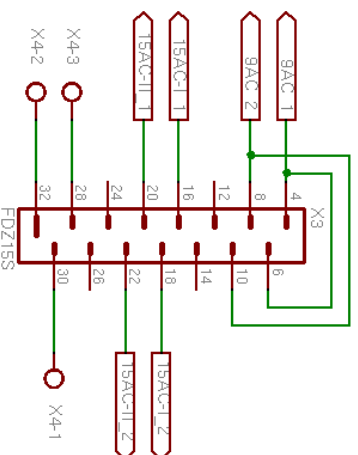
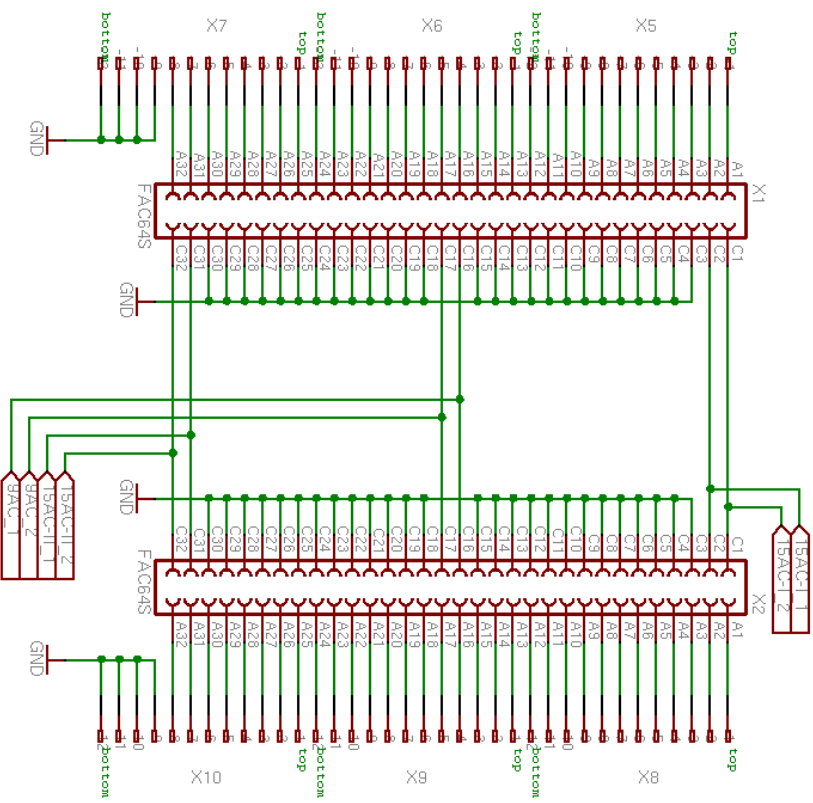

Inventronik GmbH, 2004	
Backplane Basic-Bi	
TITLE: backplane_basic-bi	
Document Number: Viplax_ED_03-2004	REV: 1.0
WF, JC, Änderungen vorbehalten	
Date: 6/01/2004 10:59:10	Sheet: 1/1

## **Repair**

In case of a faulty component, please send the device along with an exact description of the error directly to Inventronik GmbH.