

Application Manual

Real Time Clock Module

RTC-4513



SEIKO EPSON CORPORATION



*In pursuit of "Saving" Technology ,Epson electronic device.
Our Lineup of semiconductors, Liquid crystal displays and quartz devices
assists in creating the products of our customers' dreams.
Epson IS energy savings.*

NOTICE

- *No part of this material may be reproduced or duplicated in any form or any means without the written permission of Seiko Epson.*
- *Seiko Epson reserves the right to make changes to this material without notice.*
- *Seiko Epson does not assume any liability of any kind arising out of any inaccuracies contained in this material or due to its application or use in any product or circuit and, further, there is no representation that this material is applicable to products requiring high level reliability, such as, medical products.*
- *Moreover, no license to any intellectual property rights is granted by implication or otherwise, and there is no representation or warranty that anything made in accordance with this material will be free from any patent or copyright infringement of a third party.*
- *This material of portions thereof may contain technology or the subject relating to strategic products under the control of the Foreign Exchange and Foreign Trade Law of Japan and may require an export license from the Ministry of international Trade and industry or other approval from another government agency.*

CONTENTS

1. Overview	1
2. Block Diagram.....	1
3. Pin Assignment	2
4. Pin Functions	2
5. Specifications	3
5-1. Absolute Maximum Ratings	3
5-2. Operating conditions.....	3
5-3. Oscillation characteristics	3
5-4. DC characteristics	3
5-5. AC characteristics.....	4
6. Registers.....	5
6-1. Register Table	5
6-2. Register Description	6
6-2-1. Clock/Calendar Register	6
6-2-2. Control Registers	7
7. Usage	11
7-1. Function outline	11
[Write operation]	11
[Read operation]	11
7-2. Power-on procedure	12
7-3. Reading registers S ₁ to W	12
7-4. Writing registers S ₁ - W	13
7-5. Writing the 30-second ADJ bit.....	14
8. External Dimensions	15
9. Marking Layout	15
10. Reference data	16
11. Application notes.....	17
11-1. Notes on handling.....	17
11-2. Notes on packaging.....	17

Serial Interface Real Time Clock Module

RTC - 4513

- Built-in frequency adjusted 32.768 kHz quartz crystal
- Serial interface controllable by three signal lines
- Four types of fixed-period interrupts (or waveform output)
- Automatic leap year compensation
- Software 30-second adjustment function
- Wide operating voltage range (2.7 V to 5.5 V)
- Wide data preservation range (2.0 V to 5.5 V)
- Low current consumption
- Compact SOP-14 package ideal for high integration applications

1. Overview

The RTC-4513 is a serial interface real time clock with integrated quartz oscillator. It provides a wide array of features, including clock and calendar functions, as well as fixed-period interrupts, 30-second adjustment, automatic leap year compensation, and oscillation stop detection. The serial interface can be controlled by three signal lines, to keep the number of ports on the system side to a minimum. The SOP-14 package is well suited for highly integrated installations where space is at a premium, such as in portable phones, handheld terminals and many other compact electronic devices.

2. Block Diagram

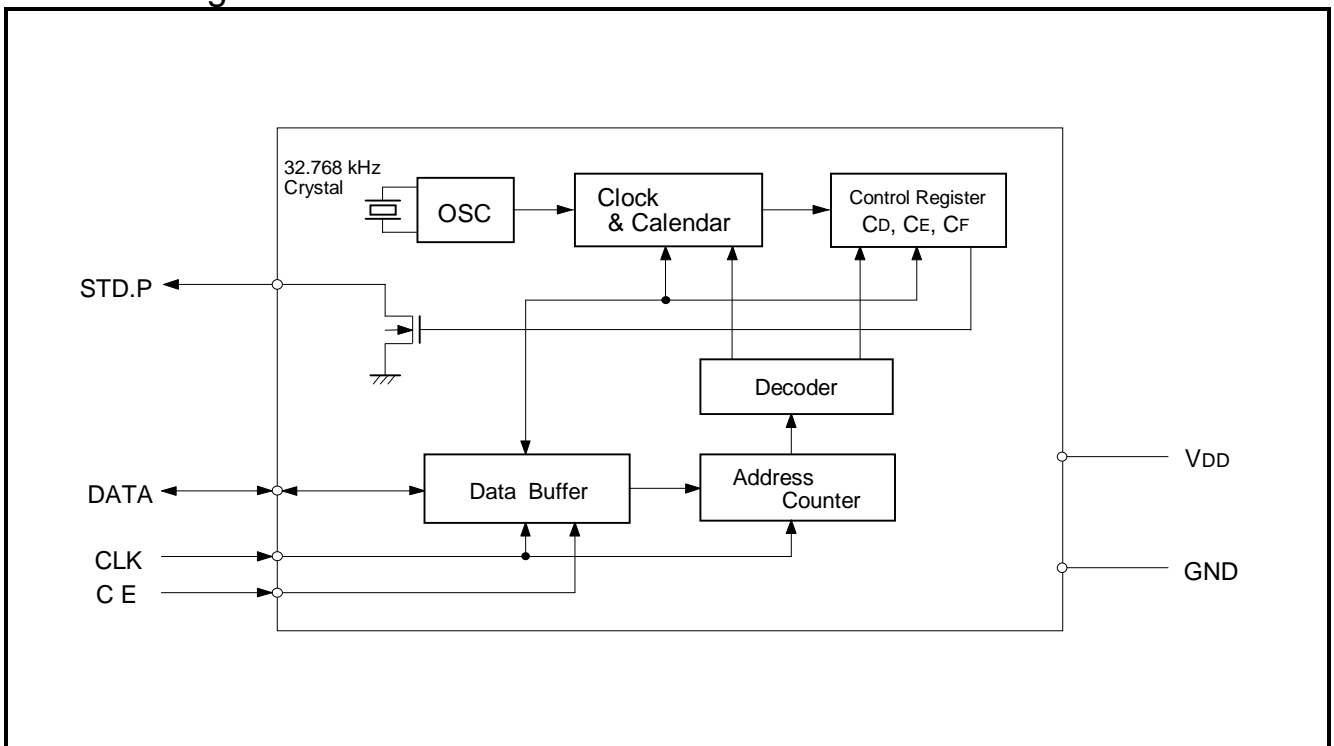

3. Pin Assignment

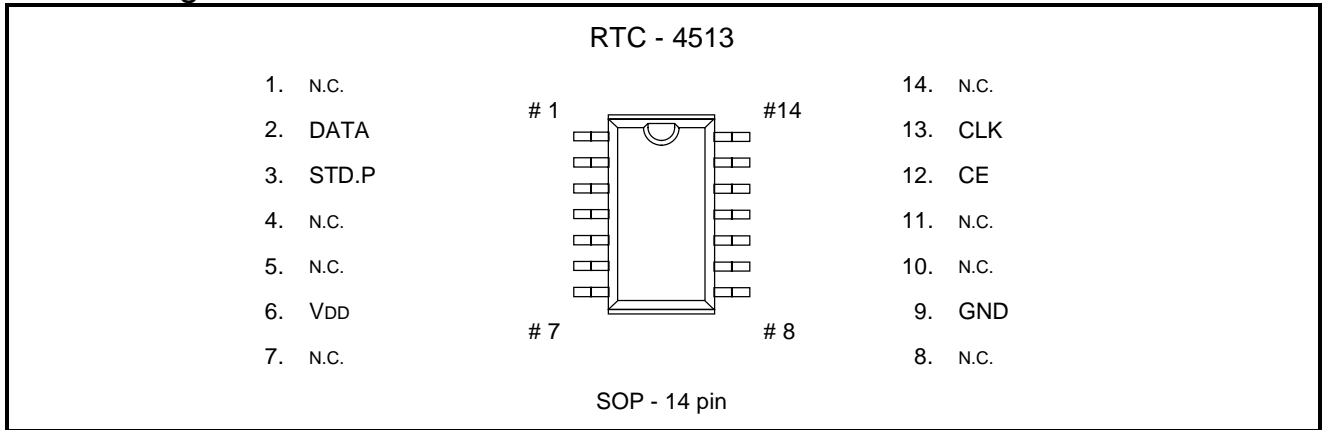

4. Pin Functions

Signal	Pin no.	I/O	Function
DATA	2	Bi-directional	This pin serves for write mode/read mode selection, address write, and data read/write operations. Becomes either a high-impedance input pin or an output pin, depending on the write mode/read mode setting in the first 8 bits of the input data after the rising edge of the CE input.
STD.P	3	Output	This pin operates as fixed-cycle open-drain output for the N channel, or as interrupt output for the CPU. The fixed-cycle output serves for verification of the reference signal or the oscillation frequency. Selection of fixed-cycle or interrupt output is performed by writing the INT/STND bit. This output is not disabled by the CE pin. (For details, refer to the section entitled "Description of Registers.")
V _{DD}	6		Connect to the positive side of the power supply. The voltage must be 2.7 to 5.5 V during normal operation and at least 2.0 V during battery backup operation.
GND	9		Connect to the negative (grounded) side of the power supply.
CE	12	Input	Chip enable input pin. When high, the chip is enabled. When low, the DATA pin goes to high impedance, the DATA pin and CLK pin are disabled within the LSI, and the feed through current is cut off. Furthermore, setting the CE pin low forcibly clears the fr, TEST, and RESET bits to "0". Note that this pin should be low when the power supply is turned on.
CLK	13	Input	Shift clock input. At the rising edge of this signal, data are read (write mode) or output (read mode).
N.C.	1,4,5,7,8,10,11,14	—	These pins are internally not connected, but to assure stable oscillation, connect them to V _{DD} externally.

* Be sure to connect a bypass capacitor of at least 0.1 μF between V_{DD} and GND.

5. Specifications

5-1. Absolute Maximum Ratings

Item	Symbol	Condition	Rating	Unit
Power supply voltage	V_{DD}	$T_a=+25\text{ }^\circ\text{C}$	-0.3 to 7.0	V
Input voltage	V_i		GND-0.3 to $V_{DD}+0.3$	
Output voltage	V_o		GND-0.3 to $V_{DD}+0.3$	
Storage temperature	T_{STG}	-	-55 to +125	$^\circ\text{C}$
Soldering conditions	T_{SOL}	Max. 2 times under 10 seconds below a temperature of +260 $^\circ\text{C}$ or for 3 minutes below a temperature of +230 $^\circ\text{C}$		

5-2. Operating conditions

Item	Symbol	Condition	Rating	Unit
Power supply voltage	V_{DD}	-	2.7 to 5.5	V
Clock power supply voltage	V_{CLK}	-	2.0 to 5.5	V
Operating temperature	T_{OPR}	No condensation	-40 to +85	$^\circ\text{C}$

5-3. Oscillation characteristics

Item	Symbol	Condition	Rating	Unit
Frequency tolerance	$\Delta f/f_0$	$T_a=+25\text{ }^\circ\text{C}$, $V_{DD}=3.0\text{ V}$	0 ± 25	$\times 10^{-6}$
Frequency Temperature characteristics	Top	-10 to +70 $^\circ\text{C}$, +25 $^\circ\text{C}$ Standard	+10 / -120	$\times 10^{-6}$
Frequency voltage characteristics	f/V	$T_a=+25\text{ }^\circ\text{C}$, $V_{DD}=2.0$ to 5.5 V	± 5 (Typ.)	$\times 10^{-6} / \text{V}$
Oscillation start time	tSTA	$T_a=+25\text{ }^\circ\text{C}$, $V_{DD}=3.0\text{V}$	3 (Max)	s
Aging	fa	$T_a=+25\text{ }^\circ\text{C}$, $V_{DD}=3.0\text{V}$ *1	± 5	$\times 10^{-6} / \text{year}$

*1) At starting year

5-4. DC characteristics

* $GND=0\text{ V}$, $V_{DD}=2.7\text{ V}$ to 5.5 V, $T_a= -40$ to +85 $^\circ\text{C}$

Item	Symbol	Condition	Min.	Typ.	Max.	Unit	Applicable pins
High input voltage	V_{IH}	-	$0.8V_{DD}$	-	-	V	Input pins
Low input voltage	V_{IL}	-	-	-	$0.2V_{DD}$	V	Input pins
Input leakage current (1)	I_{LK1}	$V_i=V_{DD}/GND$	-	-	1 / -1	μA	CE,CLK
Input leakage current (2)	I_{LK2}	$V_i=V_{DD}/GND$	-	-	10 / -10	μA	DATA
Low output voltage (1)	V_{OL1}	$I_o=1\text{ mA}$	-	-	$0.2V_{DD}$	V	DATA
High output voltage	V_{OH}	$I_o= -400\text{ }\mu\text{A}$	$0.8V_{DD}$	-	-	V	DATA
Low output voltage (2)	V_{OL2}	$I_o=1\text{ mA}$	-	-	$0.2V_{DD}$	V	STD.P
OFF leakage current	I_{OFLK}	$V_o=V_{DD}$	-	-	10	μA	STD.P
Current consumption (1)	I_{DD1}	$V_{DD}=5\text{ V}, V_i(\text{CE})=0\text{ V}$	-	10	20	μA	V_{DD}
Current consumption (2)	I_{DD2}	$V_{DD}=3\text{ V}, V_i(\text{CE})=0\text{ V}$	-	2.5	5.0	μA	V_{DD}
Current consumption (3)	I_{DD3}	$V_{DD}=2\text{ V}, V_i(\text{CE})=0\text{ V}$	-	1.0	2.0	μA	V_{DD}

5-5. AC characteristics

* GND=0V , V_{DD}=2.7 V to 5.5 V , Ta= -40 to +85 °C

Item	Symbol	Condition	Min.	Typ.	Max.	Unit
CLK H pulse width	t _{WH}	-	300	-	-	ns
CLK L pulse width	t _{WL}	-	300	-	-	ns
CE setup time	t _{CS}	-	150	-	-	ns
CE hold time	t _{CH}	-	200	-	-	ns
CE recovery time	t _{CR}	-	300	-	-	ns
CLK setup time	t _{CKS}	-	20	-	-	ns
CLK hold time	t _{CKH}	-	20	-	-	ns
Write data setup time	t _{DS}	-	50	-	-	ns
Write data hold time	t _{DH}	-	50	-	-	ns
Read data delay time	t _{RD}	CL=50 pF	-	-	250	ns
Output disable delay time	t _{RZ}	-	-	-	100	ns
Input rise time/fall time	t _{RF}	-	-	-	20	ns

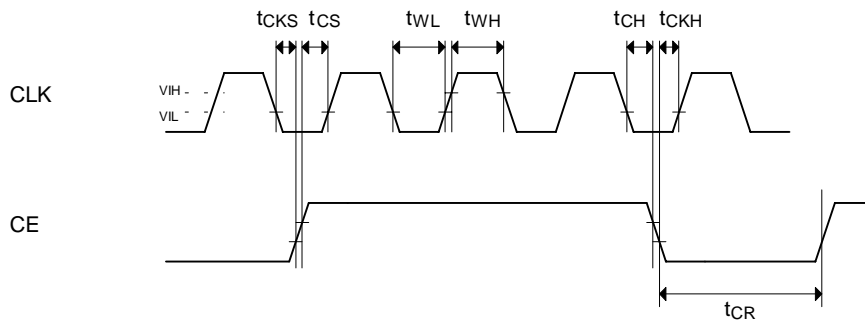

WRITE MODE

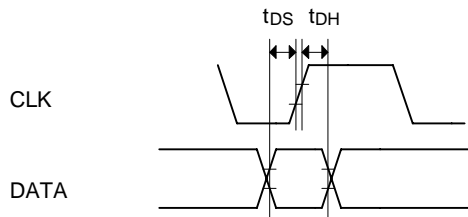

READ MODE

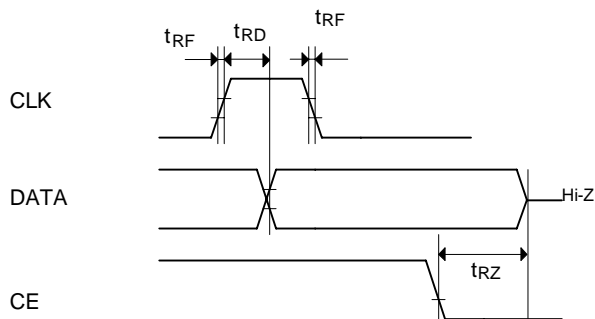

6. Registers

6-1. Register Table

Address	Register name	D3 (MSB)	D2	D1	D0 (LSB)	Count range	Remarks
0	S ₁	s8	s4	s2	s1	0~9	1-second digit register
1	S ₁₀	fo	s40	s20	s10	0~5	10-second digit register
2	MI ₁	mi8	mi4	mi2	mi1	0~9	1-minute digit register
3	MI ₁₀	fr	mi40	mi20	mi10	0~5	10-minute digit register
4	H ₁	h8	h4	h2	h1	0~9	1-hour digit register
5	H ₁₀	fr	PM/AM	h20	h10	0~1,2	10-hour digit register
6	D ₁	d8	d4	d2	d1	0~9	1-day digit register
7	D ₁₀	fr	*	d20	d10	0~3	10-day digit register
8	MO ₁	mo8	mo4	mo2	mo1	0~9	1-month digit register
9	MO ₁₀	fr	*	*	mo10	0~1	10-month digit register
A	Y ₁	y8	y4	y2	y1	0~9	1-year digit register
B	Y ₁₀	y80	y40	y20	y10	0~9	10-year digit register
C	W	fr	w4	w2	w1	0~6	Day-of-the-week register
D	C _D	30ADJ.	IRQ-F	CAL/HW	HOLD	–	Control register D
E	C _E	t1	t0	INT/STND	MASK	–	Control register E
F	C _F	TEST	24/12	STOP	RESET	–	Control register F

- The relation between register bit 0/1 and input/output is positive logic. 0 = Low; 1 = High.
- The count is in BCD code. For example, if the 1-year digit register (Y₁) is (y8, y4, y2, y1) = (0,0,1,0), the register indicates the "2" of "1992".
- Bits marked with * can be freely written to and used as RAM.
- A write instruction for the IRQ-F bit is not executed. This bit is set to "1" when the digit increment specified by t1,t0 is executed. The setting is maintained until the C_D register has been read, and then returns to "0".
- The fo (OSC FLAG) bit records any oscillation interruption. It is used to monitor for low battery voltage. The bit can be cleared by setting it to "0". (Setting the bit externally to "1" is also possible.)
- The fr (READ FLAG) bit goes to "0" when CE is set low, and goes to "1" when there is a carry to the seconds digit while a high signal is input to CE. This makes it possible to determine whether or not there was a carry to the seconds digit while the clock register was being read (i.e., while the CE input was high). If fr is "1", it is necessary to read the clock register again.
- The PM/AM bit is "1" for PM and "0" for AM.

6-2. Register Description

6-2-1. Clock/Calendar Register

(S₁,S₁₀,M₁,M₁₀,H₁,H₁₀,D₁,D₁₀,MO₁,MO₁₀,Y₁,Y₁₀,W)

- The register abbreviations stand for Second1, Second10, Minute1, Minute10, Hour1, Hour10, Day1, Day10, Month1, Month10, Year1, Year10, and Weekday. The notation is in BCD code, using numeric weighting.
- The registers are positive-logic registers. For example, (s₈,s₄,s₂,s₁) = 1001 means "9 seconds". Bits marked with* in the register table can be freely written to and used as RAM.
- Do not set impossible values to prevent the possibility of clock malfunction.
- Relation between PM/AM,h₂₀,h₁₀
 - a) 12-hour notation
Possible time settings are 12 a.m. to 11 a.m., and 12 p.m. to 11 p.m.
The h₂₀ bit cannot be written and is fixed to "0".
The clock does not increment the h₂₀ bit.
 - 24-hour notation
Possible time settings are 0 to 23.
A write attempt to the PM/AM bit is disregarded, and the bit will always read "0".
- Y₁,Y₁₀ and leap years
When using the western calendar, the last two digits of the year are assigned to Y₁ and Y₁₀. Leap years are determined by dividing the value indicated by Y₁ and Y₁₀ by four; if the remainder is "0," the year is a leap year. Leap years are automatically determined in this manner, whether the year is numbered according to the western calendar or the Heisei nengo.
Note : the year "99" is followed by "00".
- W register
For this register, count-up from 0 to 6 is performed. The table below shows an example for bit weighting.

w4	w2	w1	Day of the week
0	0	0	Monday
0	0	1	Tuesday
0	1	0	Wednesday
0	1	1	Thursday
1	0	0	Friday
1	0	1	Saturday
1	1	0	Sunday

- fo flag (OSC FLAG)
This bit records any oscillation interruption. It is used to monitor for low battery voltage. "1" means an oscillation interruption. The bit can be cleared by setting it to "0". It is also possible to externally set the bit to "1", but this should be avoided.
- fr (READ FLAG)
The fr flag is set to "1" when there was a carry to the seconds value while the CE input was high. This flag makes it possible to determine whether or not a carry to the seconds value occurred while the clock register was being read (while the CE input was high). If the fr flag is "1", the entire clock register must be read again. The fr flag is cleared by setting CE low.

6-2-2. Control Registers

● CD register

Address	Register	D3	D2	D1	D0	
D	C _D	30ADJ.	IRQ-F	CAL/HW	HOLD	Control register D

• 30-second ADJ (30-second adjustment) bit

When this bit is written, it adjusts the time to 00 seconds when the seconds value for the current time is less than 30, and adjusts the time to 00 seconds and generates a carry to the minutes value when the seconds value for the current time is 30 or more. Because internal processing is being performed for 125 μs after this bit is written, do not write the S₁ to W registers and do not write a "1" to the RESET bit during this 125 μs interval. This bit is maintained at "1" for 125 μs after it is written, and then is automatically reset to "0" afterwards. Therefore, confirm that the bit has been automatically reset to "0" before writing the S₁ to W registers.

• IRQ-F

IRQ-F goes to "1" and the STD.P output changes to low level according to the timing of the carry generation specified by the CE register bits t₁ and t₀ in combination.

a) During interrupt mode (INT/STD = "1")

After IRQ-F goes to "1", IRQ-F is maintained at "1" until the CD register read is completed. After the CD register read is completed, IRQ-F is cleared to "0".

b) Constant cycle waveform output mode (INT/STD = "0")

After approximately 7.8 ms, IRQ-F is automatically reset to "0". While IRQ-F is "1", the bit can also be cleared to "0" by reading the CD register.

The carries can be generated at one of four rates, depending on the combination of t₁ and t₀: 64 Hz, 1 second, 1 minute, or 1 hour.

• CAL/HW (clock range switching bit)

When this bit is "1", the clock range is: seconds to the tens digit for years, and weeks

When this bit is "0", the clock range is: seconds to the tens digit for hours, and weeks

When this bit is "0", the six registers from D₁ to Y₁₀ are not involved in clock operations, so they can be used as RAM for 4-bit data. The bits marked with asterisks and the fr flag portion of the D₁₀ and MO₁₀ registers can also be used as independent RAM.

• HOLD

This bit stops the 1-second digit incrementation. The clock continues to run, and the first incrementation after HOLD was set to "1" is compensated for when the hold condition is released (+1 second). The bit is cleared by writing "0".

●CE register

Address	Register	D3	D2	D1	D0	
E	C _E	t ₁	t ₀	INT/STND	MASK	Control register E

• t₁,t₀

Set the Period of the Periodic interrupt mode or fixed-period waveform mode.

t ₁	t ₀	Period
0	0	1/64 s
0	1	1 second
1	0	1 minute
1	1	1 hour

INT/STND bit = "1": interrupt mode

INT/STND bit = "0": fixed-period waveform output mode

Example t₁="1",t₀="1",MASK="0"

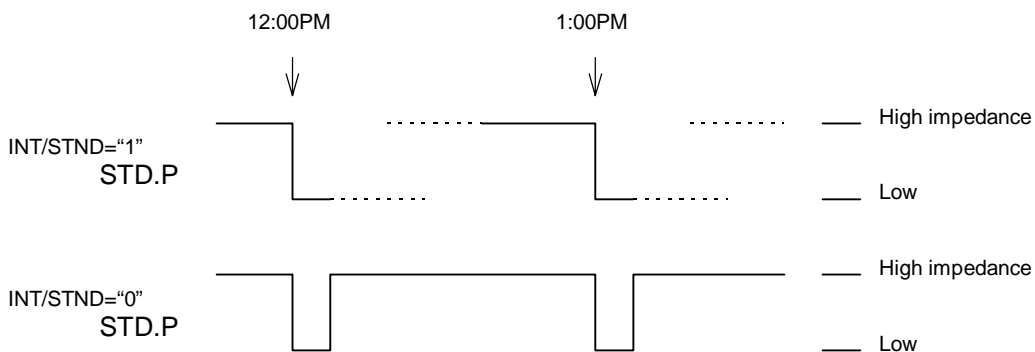

The fixed-period Low level cycle is 7.8 ms.

Because the 30-second adjustment could cause an incrementation, at the setting (t₁,t₀) = (1,0), (1,1) the STD.P output can become Low. If INT/STND = "0", the Low condition is maintained for up to 9.8 ms after the 30-second adjustment clear interval (after the 30-second ADJ flag has reverted to "0").

When the interrupt cycle is either 1 second, 1 minute, or 1 hour. If the HOLD bit is used to write S₁ - MI₁₀, and if there was an incrementation, the interrupt timing as determined by the incrementation is written to the S₁ - MI₁₀ registers and will cause the STD.P output to be Low after the hold condition is released (IRQ-F becomes "1").

Except for the above case, writing the S₁ - H₁ registers has no effect on the STD.P output.

• INT/STND (interrupt/constant cycle waveform switching bit)

When this bit is "1", the "1" status of the IRQ-F bit and the Low condition of the STD.P output are maintained until the IRQ-F (C_D register) has been read.

When this bit is "0", the IRQ-F bit reverts to "0" after 7.8 ms or earlier if the IRQ-F bit is read before that. The Low level condition of the STD.P output reverts to high impedance after 7.8 ms.

• MASK

When this bit is "1", IRQ-F cannot be "1" and the STD.P output is high impedance.

Interrupt cycle mode (INT/STND = 1)

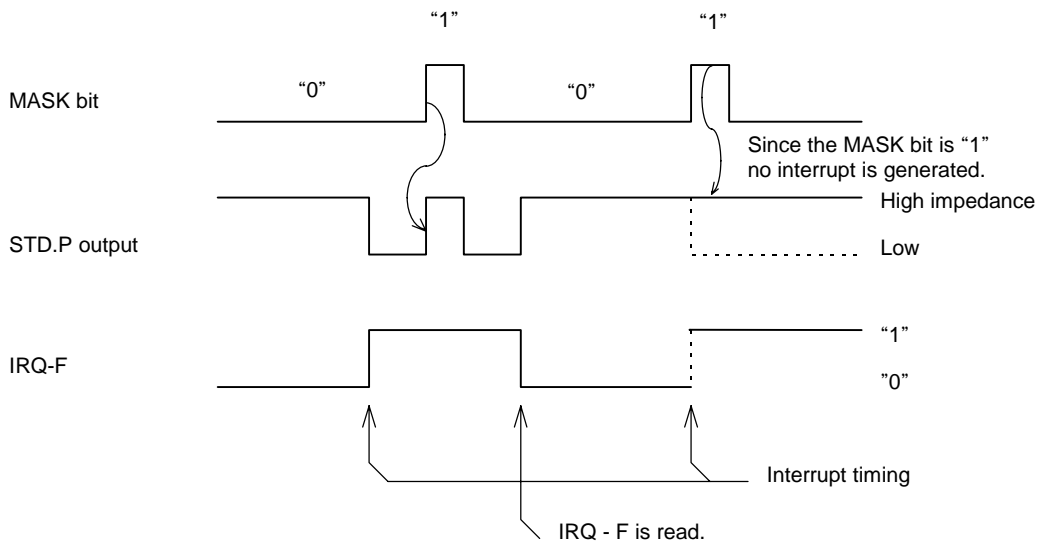

Fixed-cycle mode (INT/STND = 0)

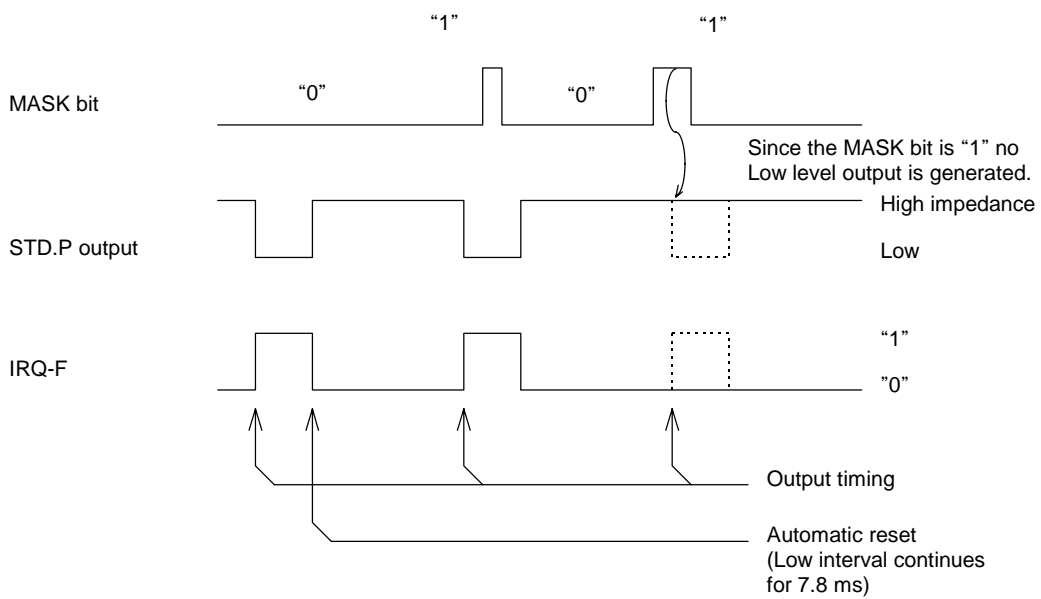

If the IRQ-F bit is read, the bit is reset to "0" at that point. The STD.P output becomes Low for 7.8 ms and then is high impedance.

- CF register

Address	Register	D3	D2	D1	D0	
F	C _F	TEST	24/12	STOP	RESET	Control register F

- TEST

This is a test bit for Epson's use. Always set this bit to "0". When writing other bits in the C_F register, be careful not to accidentally write a "1" to this bit. This bit is cleared when CE is set low.

- 24/12

Selection bit for 12-hour or 24-hour notation. "1" means 24-hour and "0" means 12-hour notation. When this bit is changed, data above H₁ can become unstable and must be reset.

- STOP

When this bit is set to "1", the clock stops. When the bit is set to "0", the clock resumes operation.

- RESET

When this bit is set to "1", the seconds are reset to zero and the clock stops. This bit is cleared when CE is set low

7. Usage

7-1. Function outline

Reads and writes are both performed in 4-bit units after the rising edge of the CE input. If the CE input falls before the input of the 4-bit units of data is completed, the four-bit write data being input at the moment the CE input fell is ignored. (The preceding data is valid, however.) Reads and writes are both performed LSB first.

[Write operation]

- 1) After setting the CE input to High, make the first 4-bit block "3" to indicate write mode, and use the next 4-bit block to specify the address.
- 2) The following 4-bit block is written to the specified address. Then the address is automatically incremented, and subsequent 4-bit blocks are written to subsequent addresses.
- 3) The address incrementation is cyclic. After address F has been written, the selection returns to address 0.

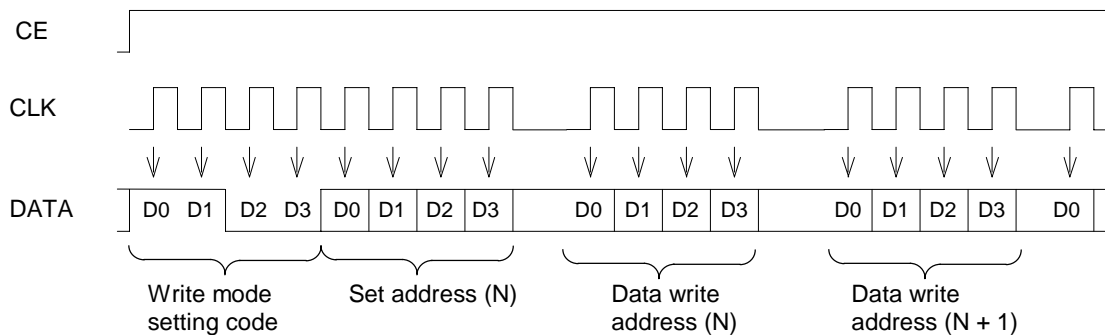

[Read operation]

- 1) After setting the CE input to High, make the first 4-bit block "C" to indicate read mode, and use the next 4-bit block to specify the address.
- 2) The four-bit data read that follows reads the data in the address that was set previously, and then the next four bits of data can be read from the automatically incremented address.

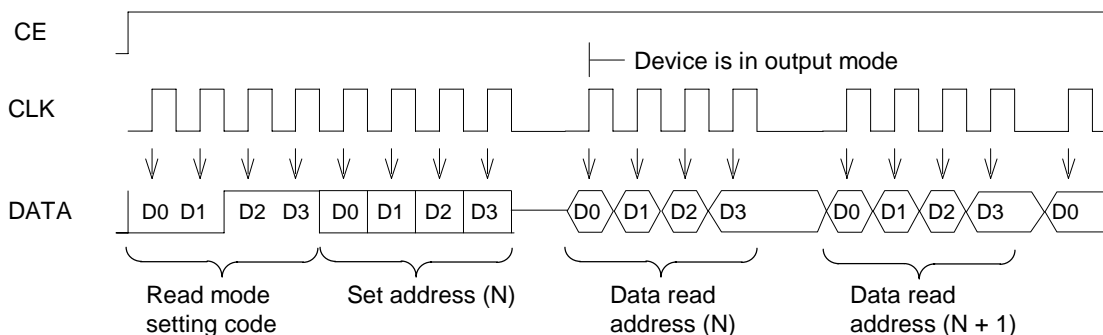

- 3) The address incrementation is cyclic. After address F has been read, the selection returns to address 0. If the mode setting code is set to something other than "C" or "3", subsequent data are disregarded and the DATA port remains in the input mode.

7-2. Power-on procedure

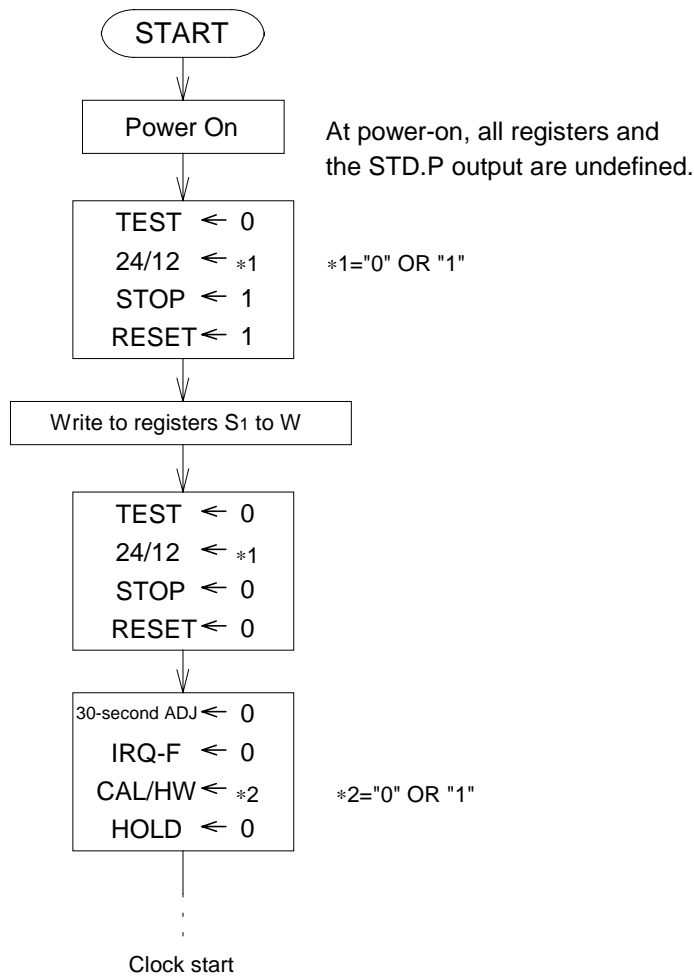

7-3. Reading registers S₁ to W

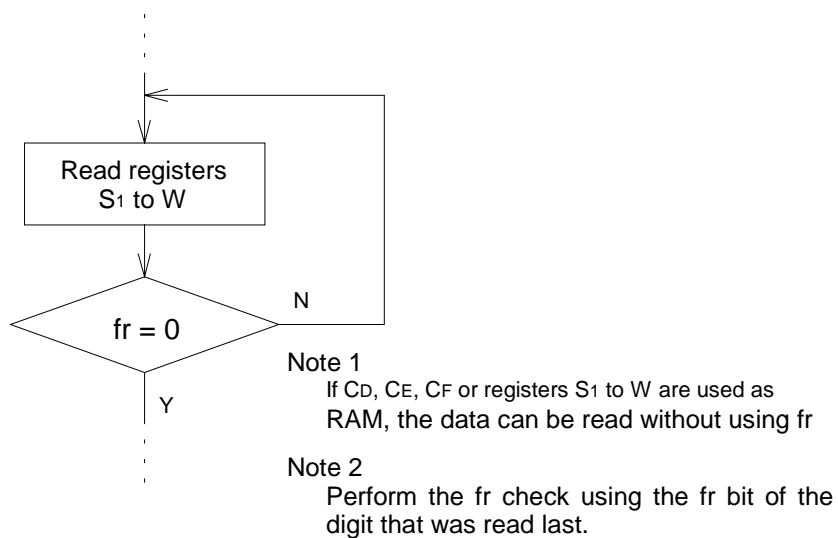

7-4. Writing registers S₁ - W

Method 1: No preservation of second data

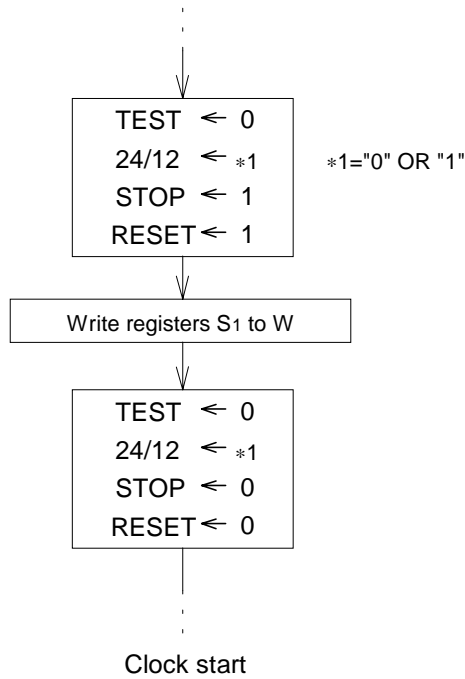

Method 2: Preservation of second data (for changeover to summer time)

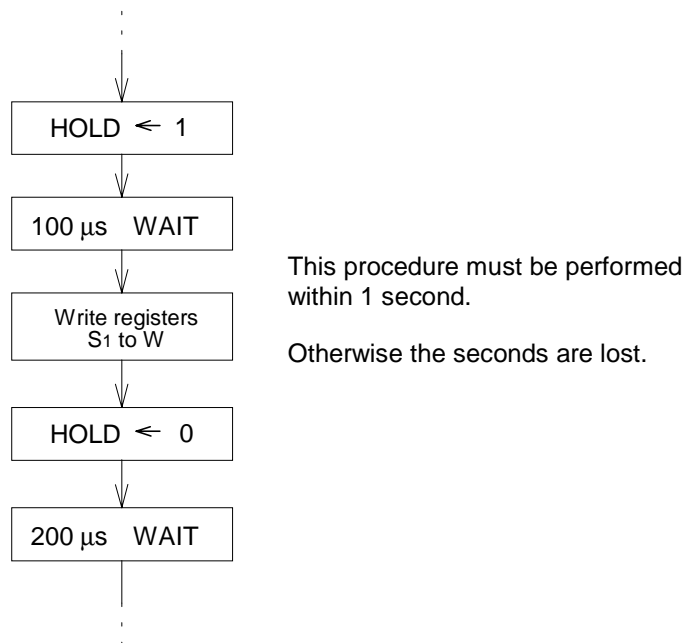

7-5. Writing the 30-second ADJ bit

Method 1

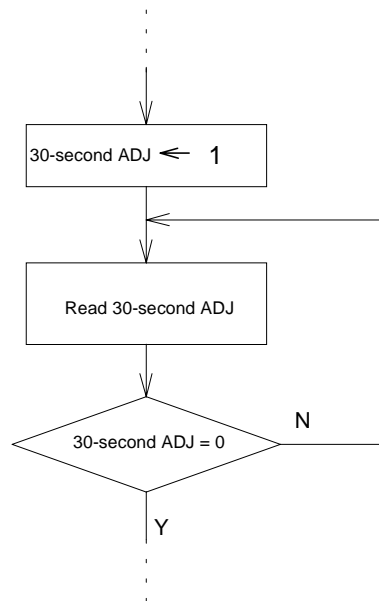

Method 2

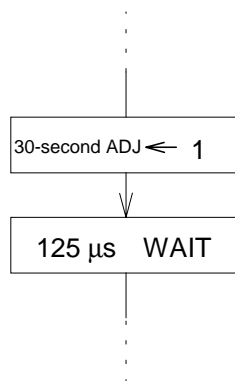

8. External Dimensions

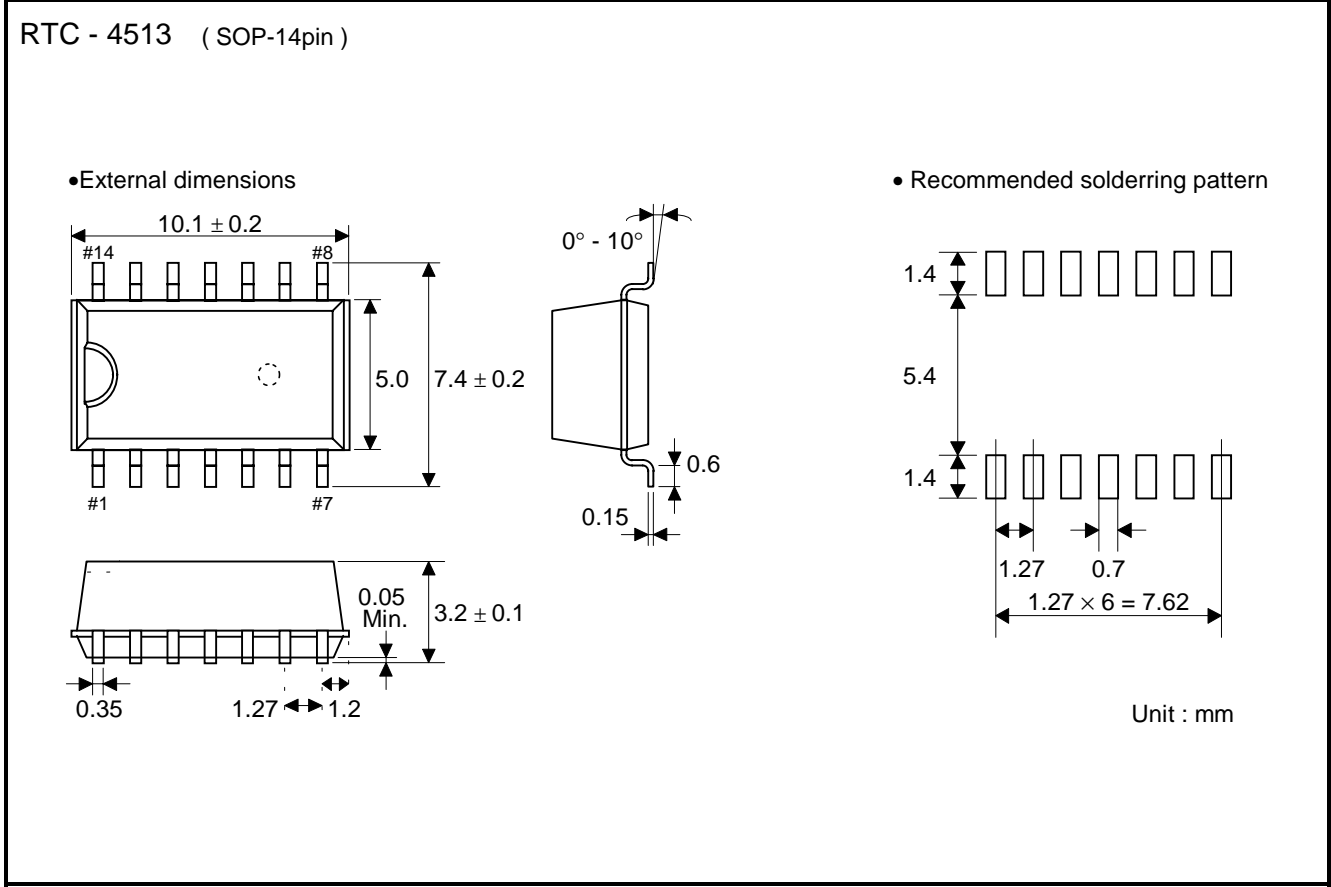

9. Marking Layout

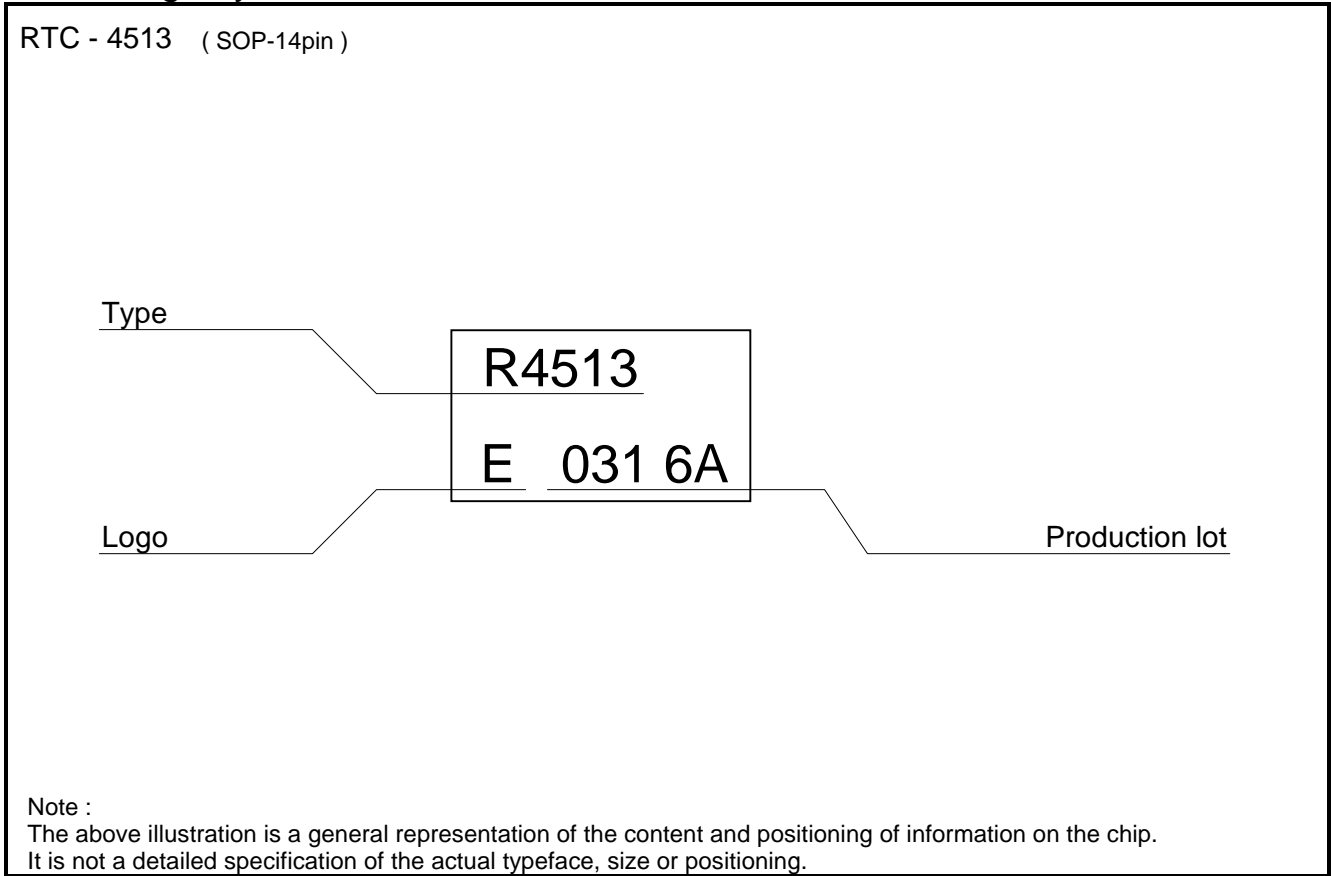

10. Reference data

(1) Frequency temperature characteristics example

Finding the frequency stability (clock accuracy)

1. The frequency temperature characteristics can be approximated by using the following formula:

$$\Delta fT = \alpha (\theta T - \theta X)^2$$

ΔfT	: Frequency deviation at target temperature
α (1 / °C ²)	: Secondary temperature coefficient ((-0.035±0.005) × 10 ⁻⁶ / °C ²)
θT (°C)	: Peak temperature (+25±5 °C)
θX (°C)	: Target temperature

2. To determine the overall clock accuracy, add the frequency precision and the voltage characteristics:

$$\Delta f/f = \Delta f/f_0 + \Delta fT + \Delta fV$$

$\Delta f/f$: Clock accuracy at a given temperature and voltage (frequency stability)
$\Delta f/f_0$: Frequency precision
ΔfT	: Temperature dependent frequency deviation
ΔfV	: Voltage dependent frequency deviation

3. Finding the daily deviation:
 Daily deviation = $\Delta f/f \times 86400$ (seconds)
 The clock error is one second per day at 11.574×10^{-6}

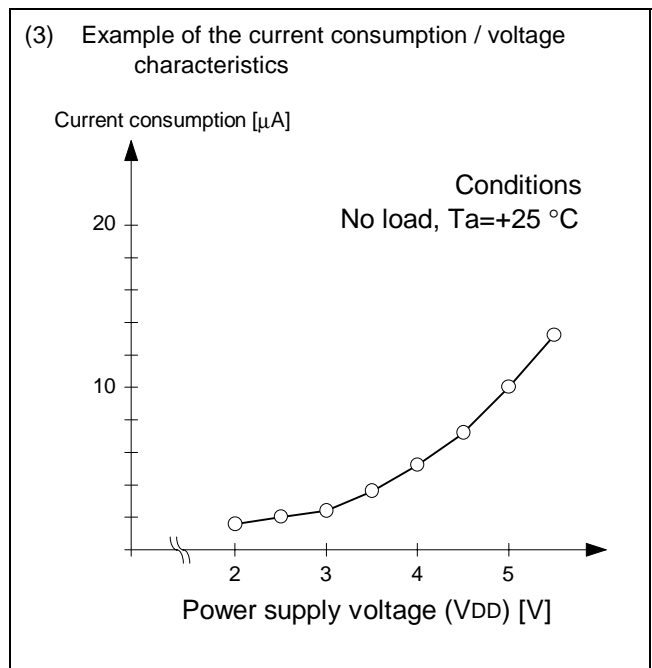
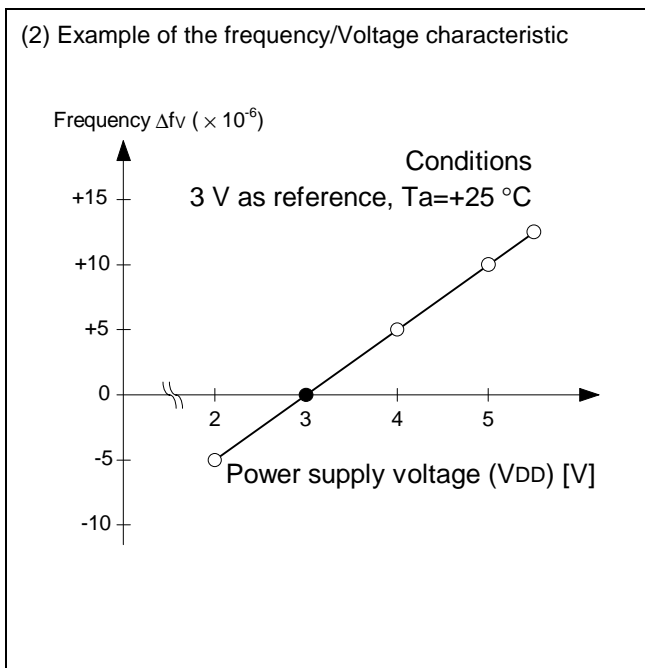

Note:
 These data show average values for a sample lot.

11. Application notes

11-1. Notes on handling

This module uses a C-MOS IC to realize low power consumption. Carefully note the following cautions when handling.

(1) Static electricity

While this module has built-in circuitry designed to protect it against electrostatic discharge, the chip could still be damaged by a large discharge of static electricity. Containers used for packing and transport should be constructed of conductive materials. In addition, only soldering irons, measurement circuits, and other such devices which do not leak high voltage should be used with this module, which should also be grounded when such devices are being used.

(2) Noise

If a signal with excessive external noise is applied to the power supply or input pins, the device may malfunction or "latch up." In order to ensure stable operation, connect a filter capacitor (preferably ceramic) of greater than 0.1F as close as possible to the power supply pins (between VDD and GNDs). Also, avoid placing any device that generates high level of electronic noise near this module.

* Do not connect signal lines to the shaded area in the figure shown in Fig. 1 and, if possible, embed this area in a GND land.

(3) Voltage levels of input pins

When the input pins are at the mid-level, this will cause increased current consumption and a reduced noise margin, and can impair the functioning of the device. Therefore, try as much as possible to apply the voltage level close to VDD or GND.

(4) Handling of unused pins

Since the input impedance of the input pins is extremely high, operating the device with these pins in the open circuit state can lead to unstable voltage level and malfunctions due to noise. Therefore, pull-up or pull-down resistors should be provided for all unused input pins.

11-2. Notes on packaging

(1) Soldering temperature conditions

If the temperature within the package exceeds 260, the characteristics of the crystal oscillator will be degraded and it may be damaged. Therefore, always check the mounting temperature before mounting this device. Also, check again if the mounting conditions are later changed.

* See Fig. 2 for the soldering conditions of SMD products.

(2) Mounting equipment

While this module can be used with general-purpose mounting equipment, the internal crystal oscillator may be damaged in some circumstances, depending on the equipment and conditions. Therefore, be sure to check this. In addition, if the mounting conditions are later changed, the same check should be performed again.

(3) Ultrasonic cleaning

Depending on the usage conditions, there is a possibility that the crystal oscillator will be damaged by resonance during ultrasonic cleaning. Since the conditions under which ultrasonic cleaning is carried out (the type of cleaner, power level, time, state of the inside of the cleaning vessel, etc.) vary widely, this device is not warranted against damage during ultrasonic cleaning.

(4) Mounting orientation

This device can be damaged if it is mounted in the wrong orientation. Always confirm the orientation of the device before mounting.

(5) Leakage between pins

Leakage between pins may occur if the power is turned on while the device has condensation or dirt on it. Make sure the device is dry and clean before supplying power to it.

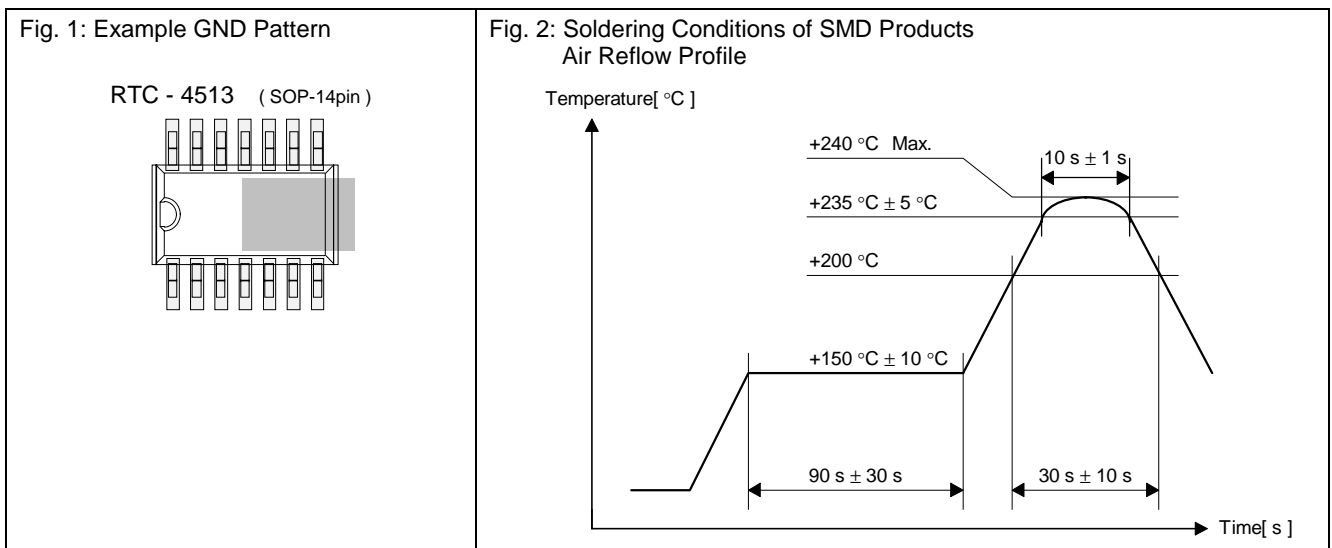

EPSON

Application Manual

Distributor

AMERICA

EPSON ELECTRONICS AMERICA, INC.

HEADQUARTER

1960 East Grand Avenue, El Segundo, CA 90245 U.S.A.

Phone (1)310-955-5300 Fax (1)310-955-5400

SALES OFFICE

150 River Oaks Parkway San Jose, CA 95134, U.S.A.

Phone (1)408-922-0200 Fax (1)408-922-0238

EUROPE

EPSON EUROPE ELECTRONICS GmbH

HEADQUARTER

Riesstrasse 15, 80992 Munich Germany

Phone: (49)-(0)89-14005-0 Fax: (49)-(0)89-14005-110

- GERMANY -

SALES OFFICE

Altstadtstrasse 176, 51379 Leverkusen Germany

Phone : (49)-(0)2171-5045-0 Fax: (49)-(0)2171-5045-10

- UNITED KINGDOM -

UK BRANCH OFFICE

Unit 2.4, Doncastle House Doncastle Road Bracknell Berkshire RG12 8PE England

Phone: (44)-(0)1344-381700 Fax: (44)-(0)1344-381701

- FRANCE -

FRENCH BRANCH OFFICE

1 Avenue de l' Atlantique LP 915 Les Conquerants Z.A. de Courtaboeuf 2 F-91976 Les Ulis Cedex France

Phone: (33)-(0)1-64862350 Fax: (33)-(0)1-64862355

ASIA

- CHINA -

EPSON (CHINA) CO., LTD.

28F, Beijing Silver Tower 2# North RD DongSangHuan ChaoYang District, Beijing, China

Phone: (86) 10-6410-6655 Fax: (86) 10-6410-7319

SHANGHAI BRANCH

4F, Bldg.,27, No.69, Guijing Road, Caoheijing, Shanghai, China

Phone: (86) 21-6485-0835 Fax: (86) 21-6485-0775

- HONG KONG CHINA -

EPSON HONG KONG LTD.

20/F., Harbour Centre, 25 Harbour Road, Wanchai, Hong kong

Phone: (852) 2585-4600 Fax: (852) 2827-2152

EPSON ELECTRONIC TECHNOLOGY DEVELOPMENT (SHENZHEN)CO., LTD.

Flat 16A, 16/F, New Times Plaza, No.1 Taizi Road, Shenzhen, China

Phone: (86) 755-6811118 Fax: (86) 755-6677786

- TAIWAN -

EPSON TAIWAN TECHNOLOGY & TRADING LTD.

10F, No.287, Nanking East Road, Sec.3, Taipei, Taiwan

Phone: (886) 2-2717-7360 Fax: (886)2-2718-9366

- SINGAPORE -

EPSON SINGAPORE PTE. LTD.

No.1, Temasek Avenue #36-00, Millenia Tower, Singapore 039192

Phone: (65) 337-7911 Fax: (65) 334-2716

- KOREA -

SEIKO EPSON CORPORATION KOREA Office

50F, KLI 63 Building,60 Yoido-dong, Youngdeungpo-Ku, Seoul, 150-763, Korea

Phone: (82) 2-784-6027 Fax: (82) 2-767-3677

SEIKO EPSON CORPORATION

ELECTRONIC DEVICE MARKETING DEPARTMENT

Electronic devices information on WWW server

<http://www.epson.co.jp/device/>